

## Indel SAC-Drives SAC drives with safety



**Made in Switzerland**

Rev 3.45 © Indel AG, 05/09/2024

Language: English

## Table of contents

<b>1</b>	<b>Safety notes.....</b>	<b>5</b>
1.1	<b>General safety notes.....</b>	<b>5</b>
1.1.1	<i>Documentation.....</i>	<i>5</i>
1.1.2	<i>Qualified personnel.....</i>	<i>5</i>
1.1.3	<i>ESD protection.....</i>	<i>5</i>
1.1.4	<i>Cut-out.....</i>	<i>5</i>
1.1.5	<i>Protection against touching electrical parts.....</i>	<i>5</i>
1.1.6	<i>Pulse inhibitor.....</i>	<i>6</i>
1.1.7	<i>Handling.....</i>	<i>6</i>
1.1.8	<i>Unidentified faults.....</i>	<i>6</i>
1.1.9	<i>Maximum movement in the event of a fault.....</i>	<i>6</i>
1.2	<b>Safety requirements.....</b>	<b>7</b>
1.2.1	<i>Risk analysis.....</i>	<i>7</i>
1.2.2	<i>Stop categories.....</i>	<i>10</i>
1.2.3	<i>Possible safety function for Indel servo drives.....</i>	<i>10</i>
1.2.4	<i>Safety functions.....</i>	<i>10</i>
1.2.5	<i>Safety criteria for STO.....</i>	<i>11</i>
1.2.6	<i>EMV.....</i>	<i>11</i>
1.2.7	<i>Commissioning.....</i>	<i>11</i>
1.2.8	<i>Intended use.....</i>	<i>12</i>
1.2.9	<i>Service life.....</i>	<i>12</i>
1.2.10	<i>Simple protection against bypassing.....</i>	<i>12</i>
1.2.11	<i>Responsibility.....</i>	<i>12</i>
1.2.12	<i>Damaged drives.....</i>	<i>12</i>
<b>2</b>	<b>Description.....</b>	<b>13</b>
2.1	<b>Rating plate.....</b>	<b>13</b>
2.2	<b>Position controller.....</b>	<b>13</b>
<b>3</b>	<b>Technical details.....</b>	<b>14</b>
3.1	<b>Technical details for Indel servo controllers.....</b>	<b>14</b>
3.2	<b>Dimensions.....</b>	<b>21</b>
3.3	<b>Installation.....</b>	<b>23</b>
3.3.1	<i>Assembly.....</i>	<i>23</i>
3.3.2	<i>24V power supply.....</i>	<i>23</i>
3.3.3	<i>Cabling.....</i>	<i>23</i>
3.3.4	<i>Other connections.....</i>	<i>24</i>
3.4	<b>Cooling and ventilation.....</b>	<b>25</b>
3.4.1	<i>Assembly and cooling of SAC3x3 drives.....</i>	<i>25</i>
3.5	<b>Network, mains connection.....</b>	<b>26</b>
3.5.1	<i>Network forms.....</i>	<i>26</i>
3.5.2	<i>Protective earth connection (PE).....</i>	<i>26</i>
3.5.3	<i>Mains filter.....</i>	<i>26</i>
3.6	<b>Parallel connection of the intermediate circuit.....</b>	<b>27</b>
3.7	<b>High-voltage test, insulation resistance test.....</b>	<b>27</b>

3.8	<b>Residual current circuit breaker</b> .....	27
3.8.1	<i>Notes on UL directive</i> .....	28
3.8.2	<i>Motor overload protection</i> .....	28
3.9	<b>Maintenance, cleaning, repair</b> .....	29
3.10	<b>Transport and storage</b> .....	29
4	<b>Safety stop</b> .....	30
4.1	<b>Stop functions as per EN 60204-1:</b> .....	30
4.2	<b>Handling in an emergency</b> .....	30
4.3	<b>Functional principle of safety stop STO</b> .....	31
4.4	<b>Diagnostic functions</b> .....	32
4.4.1	<i>Diagnostic function in the servo drive</i> .....	32
4.4.2	<i>Diagnostic function in the fieldbus controller</i> .....	32
4.5	<b>Reaction times</b> .....	33
5	<b>Pin assignment</b> .....	34
5.1	<b>Pin assignment of SAC2, SAC3 drives</b> .....	34
5.1.1	<i>Pin arrangement of SAC2, SAC3 drives</i> .....	34
5.1.2	<i>Motors, energy supply of SAC drives</i> .....	35
5.1.3	<i>Supply, encoder connections of the SAC drives</i> .....	36
5.1.4	<i>Digital IOs of SAC drives</i> .....	37
5.1.5	<i>Serial interface of the SAC drives</i> .....	37
5.2	<b>Pin assignment of SAC3x3 drives</b> .....	38
5.2.1	<i>Motors, energy supply of SAC3x3 drives</i> .....	39
5.2.2	<i>Supply, encoder connections of SAC3x3 drives</i> .....	40
5.2.3	<i>Digital IOs of SAC3x3 drives</i> .....	40
5.2.4	<i>Incremental encoder</i> .....	41
5.2.5	<i>Serial interface of SAC3x3 drives</i> .....	43
6	<b>Fieldbus systems</b> .....	43
6.1	<i>GinLink</i> .....	43
6.2	<i>Info-Link</i> .....	45
7	<b>Status LEDs</b> .....	46
7.1	<b>SAC3 indicator LEDs</b> .....	46
7.2	<b>SAC3 error LEDs</b> .....	47
7.3	<b>Emergency system</b> .....	50
7.4	<b>Error messages</b> .....	50
7.5	<b>Warnings</b> .....	50
8	<b>Standards</b> .....	51
9	<b>Sales and service</b> .....	52
9.1	<i>Manufacturer</i> .....	52
9.2	<i>Disposal</i> .....	52
10	<b>Further documentation</b> .....	52

10.1	Handbooks.....	52
10.2	Type certificate for SAC3 drives.....	53
10.3	Declaration of conformity.....	54
<b>11</b>	<b>Appendices (informative).....</b>	<b>55</b>
11.1	Requirements for safety switching devices.....	55
11.2	<i>Procedure for risk analysis and assessment</i> .....	56
11.3	<i>Delimitation of the machine</i> .....	56
11.4	Identifying hazards.....	57
11.4.1	<i>Examples of hazards</i> .....	59
11.5	Risk estimation.....	60
11.6	Risk assessment.....	62
11.6.1	<i>Examples of risk assessment</i> .....	62
11.7	Risk reduction.....	63
11.7.1	<i>Examples of protective measures for risk reduction</i> .....	64
11.8	Implementing the safety functions.....	65
11.8.1	<i>Performance level of the safety system</i> .....	65
11.8.2	<i>Mean time to failure (dangerous) (MTTFd)</i> .....	65
11.8.3	<i>Diagnostic coverage DC</i> .....	66
11.8.4	<i>Common cause failures CCF</i> .....	66
11.9	The categories and their relationship with the MTTFd of each channel, DC and CCF.....	67
11.9.1	<i>Category B</i> .....	67
11.9.2	<i>Category 1</i> .....	68
11.9.3	<i>Category 2</i> .....	69
11.9.4	<i>Category 3</i> .....	70
11.9.5	<i>Category 4</i> .....	71
11.9.6	<i>Relationship between MTTFd, DC, PL and categories</i> .....	72
11.9.7	<i>Combining safety devices</i> .....	73
11.10	Methods for troubleshooting.....	74
11.11	Verification, validation of the safety function.....	75
11.11.1	<i>Verification</i> .....	75
11.11.2	<i>Validation</i> .....	75
11.12	Technical documentation.....	75
11.13	<i>Connection examples</i> .....	76
11.13.1	<i>STO with locked safety door</i> .....	76
11.13.2	<i>STO with a safety switching device</i> .....	77
11.13.3	<i>STO with enabling switch</i> .....	78
<b>12</b>	<b>List of Figures.....</b>	<b>79</b>

# 1 Safety notes

## **Questions**

These safety notes do not claim to be exhaustive. Please call us if you have any questions or problems. (Tel. +41 44 956 20 00)

## **1.1 General safety notes**

### **1.1.1 Documentation**

Please read this documentation, and other documentation to which it refers, fully before installation and commissioning. Incorrect handling of the modules can lead to damage to persons or property. Ensure that the technical details and information on connection conditions are complied with.

### **1.1.2 Qualified personnel**

Only qualified specialist personnel may carry out work such as transport, assembly, installation, commissioning, servicing and maintenance.

National accident prevention regulations must be observed.

### **1.1.3 ESD protection**

The modules contain components that are sensitive to static charge, and that can be damaged through improper handling. Discharge the static from your body before touching the modules. Avoid contact with highly insulating materials (artificial fibres, plastic film, etc.). Place the modules on a conductive surface in a voltage-free state.

Do not touch the plug connector contacts on the drive and the connected cables, or contact pins on conductors.

### **1.1.4 Cut-out**

Control and power supply connections may be carrying voltage even when the motor is not turning. Residual voltage may remain for several minutes after switching off the operating voltage. Measure the intermediate circuit voltage and wait until the voltage has dropped below 50V.

**There is a risk of serious personal injury or property damage in the event of the impermissible removal of the required covers, improper use or incorrect installation, operation or handling.**

### **1.1.5 Protection against touching electrical parts**

In order to operate the servo drives, it is necessary for certain parts to carry voltages of more than 48V. Touching such parts may lead to potentially fatal electric shocks. There is a risk of death or serious damage to health or property.

Before switching on a drive, it must be ensured that the device is correctly connected to the earth potential. The earth connection must always be established, even if the drive is only operated for a short period.

Before switching on, live parts with more than 48V must be secured against direct contact using suitable measures.

Connections may be carrying hazardous levels of voltage even when the motor is not turning. For this reason, coming into contact with the connections when they are switched on is prohibited.

Before working on the drive, it must be disconnected from the mains and secured against switching back on.

### 1.1.6 Pulse inhibitor

The safety function Safe Torque Off is designed as a safety pulse inhibitor.

Once the pulse inhibitor has been deactivated, the drive may start again, depending on the application.

**Activating the safety function is not enough to prevent voltage running through the drive. Activating the safety function does not offer any protection against electric shock.**

### 1.1.7 Handling

Incorrect handling of the drive can lead to serious damage to persons or property.

### 1.1.8 Unidentified faults

Unidentified faults can lead to loss of the safety function. Suitable measures must be taken to justify exclusion of certain faults.

It must be ensured that a single fault does not lead to loss of the safety function. (For safety category 3, SIL 2, PL d)

### 1.1.9 Maximum movement in the event of a fault

It must be noted that a multiple fault in the IGBT bridge may result in the motor advancing briefly. The maximum angle of rotation of the motor shaft when advancing depends on the number of pole pairs in the motor used.

The following applies for permanently activated servo motors (PM synchronous motors):

$$\varphi = \frac{360^\circ}{2 * p}$$

$\varphi$      Angle of rotation  
 $p$      Number of pole pairs

The following applies for linear motors:

$$d = \frac{P}{2}$$

$d$      Distance of the motor movement  
 $P$      Distance between poles

## 1.2 Safety requirements

When installing and operating Indel drives in applications with safety-related cut-out of the drive under stop category 0 or 1 as per EN 60204-1 and fault-safe protection against restart as per EN ISO 13849-1 cat.3/PL d, all requirements in this handbook, as well as requirements to which it refers, must be complied with.

In the case of uninterrupted operation, the safety functions must be checked at periodic intervals.

Frequency of the test cycle:

- For SIL2, PL d category 3 at least 1 test per year
- For SIL3, PL e category 3 at least 1 test all 3 months
- For SIL3, PL e category 4 at least 1 test per day

Indel servo drives with the STO function have been developed in accordance with the applicable standards.

### 1.2.1 Risk analysis

The machine manufacturer must compile a risk analysis for the machine and take suitable measures to ensure that unforeseen movements do not cause damage to persons or property.

Notes on possible risks are also provided in other places throughout this document. All notes on risks, warnings, precautions and information must be observed.

#### **Run-on**

If application-dependent risks arise due to run-on, additional protective measures (e.g. moveable covers with locking) must be taken to cover the danger zone until such a time that the risk to persons or property no longer exists.

It must be noted that run-on of the drive is possible without a mechanical brake or defective brake. The securing brake is not safely controlled by the Indel servo drives. (Active output)

#### **Braking resistance**

The braking resistor is not safely controlled by the Indel servo drives. A defective or incorrectly connected braking resistor will result in the motor not stopping within the expected time span. In unfortunate cases, this can lead to personal injury or property damage.

#### **Protection against burning**

The heat sinks of the SAC3x3 drives can reach temperatures of up to 80°C. The SAC3x3 drives are labelled with the following warning sign:



Figure 1: Warning: "Hot surface"

The surface of the SAC3 drives remains below 70°C.

**Residual energy, capacitor discharge**

Residual energy may remain in the intermediate circuit capacitors for up to 5 minutes after the power supply is switched off (opening the main contactor and/or motor contactor). It is possible for the motor to be moved using this residual energy. If additional external capacitor modules are used, the time until the residual energy has been discharged will be correspondingly longer.

Caution!  
Hazardous  
voltage  
remains for  
5 minutes  
after  
removing  
main power  
supply.

**Safety covers**

Additional safety covers must be designed and integrated in accordance with the safety category required for the machine as per EN ISO 13849-1. Once the stop command has been triggered, access must be blocked (locking), depending on the danger posed, until the drive has come to a complete stop, or the access time must be determined in order for the resulting safety distance to be maintained.

**Protection from dangerous movements**

Incorrect control of motors can trigger unwanted and dangerous movements.

Such behaviour may be caused by, for example:

- Faulty installation
- Faulty conFig.uration
- Faulty or incomplete wiring
- Defective devices or cables
- Faulty control by the software

Essentially, movement of the motor should be expected as soon as the drive is switched on. Protection of persons and the machine can only be guaranteed by means of overarching safety measures.

Suitable measures must be taken to ensure that the movement zone of machines are protected against unintentional access by persons.

Removing, bypassing or circumventing the safety mechanisms is strictly prohibited.

Plenty of easily accessible emergency stop switches must be available in and around the machine.

Keep all covers and control cabinet doors closed during operation. There is a risk of death or serious damage to health or property if you touch live parts (e.g. clamps).

Never disconnect the electrical connections of the modules when they are switched on and carrying voltage. In unfortunate cases, this can result in electric arcs, which can injure persons and damage items such as contacts.



***Suspended loads***

In the case of suspended loads, additional measures must be taken to ensure that the axis stays in place. The Indel servo drives do not offer outputs that allow you to safely control securing brakes. Holding brakes do not offer any protection when slowing down the motor.

***Further notes***

The emergency stop function may not necessarily lead to the energy supply being switched off. Drives may remain in operation. Protection against touching live parts is therefore not necessarily guaranteed.

Position switches and actuating controls must be secured against shifting in accordance with EN1088.

The reaction in the event of a power cut must be considered.

***Loss of the 24V supply***

The motor may spin out in the event of loss of the 24V power supply to the drive. If this is not permissible, external measures must be taken to prevent the axis from spinning out.

***Loss of the 3x400V supply***

The motor may spin out in the event of loss of the 3x400V power supply to the motors. If the intermediate circuit voltage  $U_{CC}$  falls below the configured limit  $U_{CC\ MIN}$ , the motor control will go into error mode and the motor will be switched off.

### 1.2.2 Stop categories

Indel servo drives with the ordering option STO can carry out a stop under category 0 or 1 in accordance with EN 60204-1 with the corresponding external safety switching devices.

**Note on the stop categories**

In the case of stop category 0, the 24V can be switched off at any time for both safety relays on the servo drive (hereinafter referred to as safety-related 24V power supply), regardless of the target values. It must be noted that the motor will spin out in this case.

For stop category 1, the following procedure must be followed:

- Switch off the external enabler  
The drive triggers the braking ramp independently, if this has been configured correctly
- The safety switching device separates the safety-related 24V power supply for both safety relays with a time delay
- The unit must be prevented from accidentally restarting using the external safety switching device.

### 1.2.3 Possible safety function for Indel servo drives

Order number	Option	Type	Safety category
610838842	16A/STO	GIN-SAC3	<sup>1)</sup>
610838844	24A/STO	GIN-SAC3	<sup>1)</sup>
610838845	2.5A/STO	GIN-SAC3	<sup>1)</sup>
610838846	4A/230V/STO	GIN-SAC3	<sup>1)</sup>
610838848	5A/STO	GIN-SAC3	<sup>1)</sup>
610736940	5A/230V/STO	GIN-SAC3x3	<sup>1)</sup>
610941700	5A/400V/STO	GIN-SAC3x3	<sup>1)</sup>

1) See section 1.2.4 Safety functions and 1.2.5 Safety criteria for STO

### 1.2.4 Safety functions

EN 61800-5-2	EN 60204-1
STO (Safe Torque off)	Stop category 0 Cut-out of the energy supply
SS1 (Safe Stop	Stop category 1 Introduction of active braking and activation of the STO function after a defined period of time. <sup>1)</sup>

## 1.2.5 Safety criteria for STO

Criterion	Parameter
Max. performance level as per EN ISO 13849	PL e, cat. 4
Max. Safety integrity Level gem. IEC 62061	SIL 3
PFH (Probability of dangerous Failure per Hour)	2.47E-008
DC (Diagnostic Coverage)	99% (high)
CCF (Common Cause Failure)	30.00%
MTTFd (Mean Time To Failure dangerous)	100 years

More details on STO switching can be found in section 4.3 Functional principle of safety stop STO.

## 1.2.6 EMV

For EMC-compliant wiring, see the Indel wiring guidelines, as well as the wiring instructions in this document.

The manufacturer of machines or systems must take additional EMC safety measures if the product standard applicable to their machine stipulates lower limit values. Additional EMC safety measures may also be required for machines that contain a large number of Indel servo drives. In such cases, the installation of a central mains filter is usually sufficient.

Additional measures must be implemented in order to filter out interference when using Indel servo drives in residential areas or when connecting Indel servo drives to a low-voltage network that will supply buildings in residential areas without intermediate transformers.

In order to reduce EMC interference, it is recommended that you place a corresponding filter directly beside the drives; the cable length between the filter and the drives should not be longer than 30cm.

## 1.2.7 Commissioning

Before switching on a servo drive, it must be ensured that the device is correctly connected to the earth potential. The earth connections must always be put in place, even if the drive is only being put into operation for testing purposes.

Control and power supply connections may be live even when the motor is not moving. Coming into contact with the connections when they are switched on is prohibited.

Before working on the servo drives, they must be disconnected from the mains and secured against switching back on.

The commissioning must be documented and proof of the safety functions must be kept.

Commissioning tests of the cut-out mechanism and correct wiring must essentially be carried out and logged for Indel servo drive applications with safety-related cut-out of the drive under stop category 0 or 1 as per EN 60204-1 and fault-safe protection against restart as per EN ISO 13849 cat. 3.

During commissioning, signal recognition must be included in the function test. The condition of the auxiliary contacts of the safety relays can be viewed in the actual parameters in the servo drive (This display is not safety-related).

### 1.2.8 Intended use

The Indel servo drives must only be used within the framework specified in this document and other documents to which it refers.

Intended use is prohibited until it has been established that the machine complies with the provisions of EC Directive 2006/42/EC (Machinery Directive) and Directive 2004/108/EEC (EMC Directive), or the relevant current version of said directives. Otherwise, the Indel servo controllers cannot be marketed.

Indel servo drives are designed for installation in fixed electrical machines/systems that meet the requirements of the Machinery Directive, Low Voltage Directive and EMC Directive.

Indel servo drives must be installed in a control cabinet that can only be opened with a tool. The drives must be installed in such a way that no voltage-carrying parts can be touched.

Additional measures must be taken for use in areas at risk of explosion, such as flame-proof enclosure in accordance with EN 50014 and EN 50018.

### 1.2.9 Service life

The safety module in the Indel servo drives must be replaced no later than 15 years after delivery. Safe operation can no longer be guaranteed in the event of use going beyond 15 years. This applies not only to the operating time but also to down time and storage time.

### 1.2.10 Simple protection against bypassing

Measures must be taken to prevent bypassing of the safety functions in accordance with EN ISO 13849-1 cat.3/PL d.

### 1.2.11 Responsibility

The servo drives are not completely safe from failure, particularly the safety functions. In the event of failure, the operator is responsible for ensuring that the machine/system is put into a safe condition.

**All diagnosis and monitoring functions can only interrupt the control of the motor. This means that the motor becomes currentless and can no longer be controlled or slowed down!**

**Depending on the application, additional measures are required to slow down or stop the motor.**



**The operator is responsible for safety.**

### 1.2.12 Damaged drives

Under no circumstances may damaged drives be put into operation. This could lead to serious personnel injury or property damage.

## 2 Description

### 2.1 Rating plate

<b>GIN-SAC3</b>		<b>Servo-Drive</b>	
610838846-4A/230V/STO/S9		Serie-Nr 1238-2011	
Power Supply	1x110...230Vac 50/60Hz	 	
Power S1	1.3kVA		
Protection Type	IP20		
INDEL AG Tuefswis 26 CH-8332 Russikon			HW
			GAL

Series number 1238-2011

↑  
Series number    Year of construction

S1 operation    Continuous operation with nominal

Fig. 1: Rating plate

### 2.2 Position controller

#### **PID controller**

The user has access to 3 different PID2 parameter sets (forwards, backwards, stand-by). This allows changes in load to be dealt with in the best possible way.

#### **Computational power**

The PowerPC 405-300MHz assumes the following tasks in a 8 ... 32kHz cycle:

- PID position controller, speed regulation, active current regulation
- 2. Target value: torque regulation
- Measuring wheel correction (inc encoder)
- Limitation for:  $I_{MAX}$ ,  $I^2t$ , controller, motor temperatures
- Logger for 64 freely selectable parameters
- Customer-specific application

#### **Position detection**

- Resolver: single or multi-pole, 16-bit resolution per resolver revolution
- SinCos encoder: 4096 periods per revolution, 16-bit resolution
- Incremental encoder: up to 20,000 increments (incl. 4Q resolution)
- SSI, Endat, Hiperface interface

#### **Operational safety**

A number of variables are continually monitored within the servo drives: short-circuit monitors switch off the controller in the case of motor or ground short-circuit.

Rapid overcurrent cut-outs protect the motor and output stage within the individual phases. These intervene when the drive is stuck or is stopped suddenly.

The motor and output stage are monitored for overheating.

### 3 Technical details

**It is the user's responsibility to comply with the operating and ambient conditions. Indel accepts no liability in the event of non-compliance.**

#### 3.1 Technical details for Indel servo controllers

##### Ambient conditions

Ambient conditions		SAC-Drives
Supply voltage 1-phase operation	VAC	1 x 110 ... 230 ± 10%
Supply voltage 3-phase operation (not all servo drives are approved up to 400VAC)	VAC	3 x 110 ... 400 ± 10%
Network asymmetry max.		± 3%
Mains frequency	Hz	50 / 60
Intermediate circuit voltage at 230V supply	VDC	325
Overvoltage cut-out at 230V supply	VDC	400 ±5V
Intermediate circuit voltage at 400V supply	VDC	565
Overvoltage cut-out at 400V supply	VDC	800 ±10V
Overheating cut-off	°C	80
Permissible network types with earthed neutral point		TT, TN
Switch-on interval	S	> 10
Switch-on current	A	< 2
Ambient temperature: Storage	°C	-20 ... 80
Ambient temperature: Operation <sup>1)</sup>	°C	0 ... 40
Heat sink temperature max.	°C	80
Relative humidity, no condensation	°C	80.00%
Protection class		IP-20
Degree of contamination		2 (EN 50178)
Overvoltage category		II (EN 50178)
Permissible installation altitude without reduction in performance	Metres above sea level	1000
Permissible installation altitude with reduction in performance	Metres above sea level	2000 -1.0 % / 100m
Installation position		vertical
Vibration as per IEC 68-2-6 Amplitude, frequency response	mm Hz	0.35 10 ... 120
Shock	g	1
Interference emission, industrial zone		EN 61000-6-4
Interference resistance, with mains filter, industrial zone		EN 61000-6-2
Electrical safety (voltage clearances)		EN 50178

1) To keep the ambient temperature below 40°C you may need to install additional cooling measures

**24V supply**

Logic supply		GIN-SAC3	INFO-SAC3	INFO-SAC3x3	GINSAC3x3
Operating voltage, galvanic isolation in drive	VDC	24V -5% +15%			
External fusing, fast	A	8			
Max. potential between earth and 0V	VDC	50			
Power consumption at 24V	mA	480	380	500	400

**Motor**

Motor		SAC-Drives	SAC3x3-Drives
Minimum inductance	mH	1	1
Minimum resistance	Ohm	0.2	0.2
Max. Cable length in the case of cable lengths > 20m use choke 0.5 ... 1mH	m	20	20
Motor monitoring (Bi-metal sensor must be in motor cable)		Bi-metal KTX-84 100 / 110 PTC 10k GT2	KTX-84 100 / 110 PTC 10k GT2
Accuracy of analogue temperature sensors	°C	± 2	± 2
Motor cable		shielded	shielded
Nominal motor voltage at 230VAC supply, minimum	VDC	325	325
Nominal motor voltage at 400VAC supply, minimum	VDC	565	565
Motor types: - Brushless asynchronous motors and synchronous servo motors - DC motors - Linear motors The motors must be designed for operation using digital servo drives			

**Absolute feedback systems**

Digitale Encoder	SAC-Drives
Endat 2.1	<input checked="" type="checkbox"/>
Endat 2.2	a.A.
Synchronous serial interface, max. Telegram length	Bit 32
Hiperface	<input checked="" type="checkbox"/>
Bizz	a.A.

An incremental encoder can also be connected to the absolute feedback inputs.

**Resolver**

Resolver inputs		GIN-SAC3 INFO-SAC3	GIN-SAC3x3 INFO-SAC3x3
Resolution	Bit	16	16
Reference, bridge circuit	Vrms	4	4
Sine/cosine input	Vrms	2	2
Multi-pole resolvers		<input checked="" type="checkbox"/>	<input checked="" type="checkbox"/>
Resolver cable		Pair-twisted, double shielded	

**Incremental encoder**

Incremental encoders can be connected to different interfaces. Corresponding levels and sampling rates are supported depending on the input. We generally recommend the use of an incremental encoder with RS422 level as per the current industry standard.

Incremental encoder inputs		INFO-SAC3	GIN-SAC3	GIN-SAC3x3 INFO-SAC3x3
Level at incremental encoder inputs		RS422 <sup>1)</sup> / 5V	RS422 <sup>1)</sup> / 5V	-
Max. Counting frequency of incremental encoder track	MHz	2.5	2.5	-
Level at SinCos inputs		RS422 <sup>1)</sup>	RS422 <sup>1)</sup>	RS422 <sup>1)</sup>
Max. Counting frequency for incremental encoder at SinCos input	kHz	250	250	250
Level at absolute feedback system		-	RS422 <sup>1)</sup>	RS422 <sup>1)</sup>
Max. Counting frequency for incremental encoder at absolute feedback system inputs	MHz	-	2.5	2.5
Voltage supply for encoders		5V / 200mA	5V / 200mA	5V / 200mA
Encoder cable		shielded	shielded	shielded

1) In accordance with the RS422 standard, each input is equipped with 120 Ohm resistance. The encoder must be able to handle this load.



**SinCos encoder**

Sin/Cos inputs		GIN-SAC3 INFO-SAC3	GIN-SAC3x3 INFO-SAC3x3
Level	Vrms	1	1
Differential input resistance	Ohm	120	120
Max. Periods / s <sup>1), 2)</sup>	kHz	200	200
Voltage supply for encoders		5V + 10% / 200mA	5V + 10% / 200mA
Voltage supply for encoders		10V + 10% / 100mA	10V + 10% / 100mA
Resolver cable		pair-twisted double shielded	pair-twisted double shielded

1) Analogue inputs: The maximum sampling rate for analogue inputs is 450kHz, or 250kHz with a multiplexer.

2) For incremental encoder to Sin/Cos input see "Incremental encoder" table.

**Digital inputs and outputs**

Digital inputs and outputs		GIN-SAC3	INFO-SAC3	INFO-SAC3x3	GINSAC3x3
Optocoupler outputs	V <sub>OFF</sub>	48	48		
24V outputs (resistant to short-circuiting)	V <sub>OUT</sub>			18 ... 32	18 ... 32
Constant current of 24V outputs	A	0.5	0.5	1	1
External enabler input U <sub>ON</sub>	V	18 ... 32	18 ... 32	18 ... 32	18 ... 32
External enabler input I <sub>ON</sub> @ 24V	mA	15	15	1	1
Digital inputs U <sub>ON</sub>	V			18 ... 32	18 ... 32
Digital inputs I <sub>ON</sub> @ 24V	mA			1	1
Input filter	us	250	250	250	250
Switching delay of outputs	ms	2	2	0.5	0.5
Galvanic isolation of inputs and outputs		<input checked="" type="checkbox"/>	<input checked="" type="checkbox"/>	<input type="checkbox"/>	<input type="checkbox"/>

**Safety stop STO**

Safety stop STO (pin X100)		SAC-Drives
Elesta relay		SIS 212
Supply to 24V_R1 / 24V_R2	VDC	24 ± 10%
Nominal current at 24V (per relay)	mA	25
Switching current (K1, K2)		5mA ... 6A
Fusing of the contacts and relays	A	6
Reaction time t <sub>ON</sub>	ms	10
Reaction time t <sub>OFF</sub> (without wiring)	ms	15
Life span, 24VDC/0.3A ohmic load (switching cycles)		10 x 10 <sup>6</sup>
Life span, 24VDC/6A ohmic load (switching cycles)		300'000
Bounce time	ms	2 ... 15

**Supply voltage, nominal currents of SAC drives**

Nominal values	GIN-SAC3 INFO-SAC3 INFO-SAC2	2.5A	5A	16A	24A	4A/230V
I <sub>RATED</sub> at 8kHz sampling rate	Arms	2.5	5	16	24	4
I <sub>MAX</sub> at 8kHz sampling rate	Arms	7.5	15	32	48	12
I <sub>RATED</sub> at 12kHz sampling rate	Arms	2.1	4.2	13.7	20.6	4
I <sub>MAX</sub> at 12kHz sampling rate	Arms	6.3	12.6	26.4	41.2	12
I <sub>RATED</sub> at 16kHz sampling rate	Arms	1.8	3.7	12	18	3.4
I <sub>MAX</sub> at 16kHz sampling rate	Arms	5.6	11.2	24	26	10.3
I <sub>RATED</sub> at 24kHz sampling rate	Arms	1.5	3	9.6	14.4	3
I <sub>MAX</sub> at 24kHz sampling rate	Arms	4.5	9	19.2	28.8	9
I <sub>RATED</sub> at 32kHz sampling rate	Arms	1.2	2.5	8	12	2.4
I <sub>MAX</sub> at 32kHz sampling rate	Arms	3.7	7.5	16	24	7.2
I <sub>MAX</sub> brake IGBT	Arms	7.5	15	32	48	12
External braking resistance	Ohm	60	30	25	15	30
Supply	VAC	110 ... 400	110 ... 400	110 ... 400	110 ... 400	110 ... 230
Phases		1,3	1,3	1,3	1,3	1,3
External fusing, Triggering characteristic: Slow, C	A	6	10	25	40	10
Power dissipation	W	30	60	180	200	30
Intermediate circuit capacity	uF	160	240	590	590	720
Weight	Kg	2.4	2.5	4.1	4.1	2.4

**Supply voltage, nominal currents of SAC3x3**

Nominal values <sup>1)</sup> GIN-SAC3x3 INFO-SAC3x3		15A/230V	15A/400V <sup>2)</sup>	15A/400V		
Number of output stages		3	3	3		
I <sub>RATED</sub> at 8kHz sampling rate	Arms	15	15	7.5		
I <sub>MAX</sub> at 8kHz sampling rate	Arms	21	21	10.5		
I <sub>RATED</sub> at 12kHz sampling rate	Arms	12.9	12.9	6.5		
I <sub>MAX</sub> at 12kHz sampling rate	Arms	20.5	20.5	10		
I <sub>RATED</sub> at 16kHz sampling rate	Arms	11.2	11.2	5.6		
I <sub>MAX</sub> at 16kHz sampling rate	Arms	18	18	9		
I <sub>RATED</sub> at 24kHz sampling rate	Arms	9	9	4.5		
I <sub>MAX</sub> at 24kHz sampling rate	Arms	14.4	14.4	7.2		
I <sub>RATED</sub> at 32kHz sampling rate	Arms	7.5	7.5	3.8		
I <sub>MAX</sub> at 32kHz sampling rate	Arms	12	12	6		
Supply	VAC	110 ... 230	110 ... 400	110 ... 400		
I <sub>MAX</sub> brake IGBT	Arms	24	24	24		
External braking resistance	Ohm	15	30	30		
Phases		1,3	1,3	1,3		
External fusing, Triggering characteristic: Slow, C	A	20	20	20		
Power dissipation	W	120	250	120		
Intermediate circuit capacity	uF	1410	940	940		
Weight	Kg	4.2	4.2	4.2		

1) Applies to all drives  
 The drives can be operated for a duration of 5s at I<sub>MAX</sub>.

Each individual output stage of the SAC3x3 can provide the currents in the table. The sum of the currents of all 3 output stages must not exceed the values in the table.

In the case of sampling rates of over 12kHz, it is no longer possible to operate all 3 output stages of the SAC3x3 drives as the computational power will no longer be sufficient.

The current reduction values for higher sampling rates are simply reference values and can vary depending on the application.

2) Specifications only achievable with additional ventilation of the heat sink.

### 3.2 Dimensions

#### Dimensions of INFO-SAC3 / GIN-SAC3

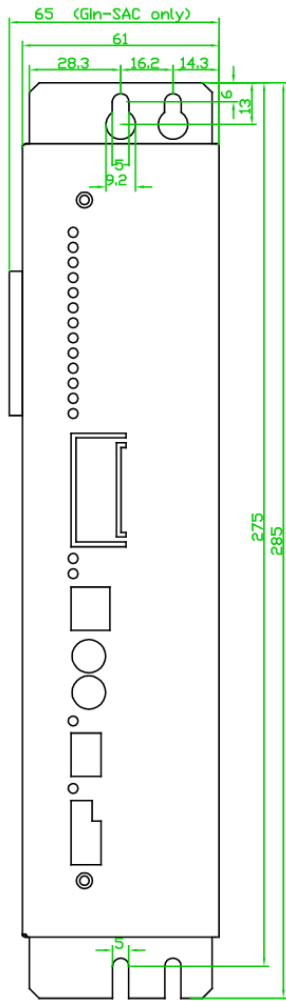

Fig. 2: SAC 2.5A, 4A/230V

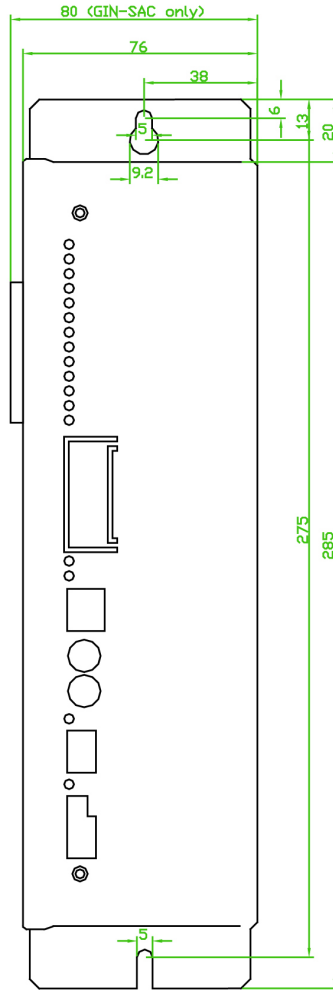

Fig. 3: SAC 5A

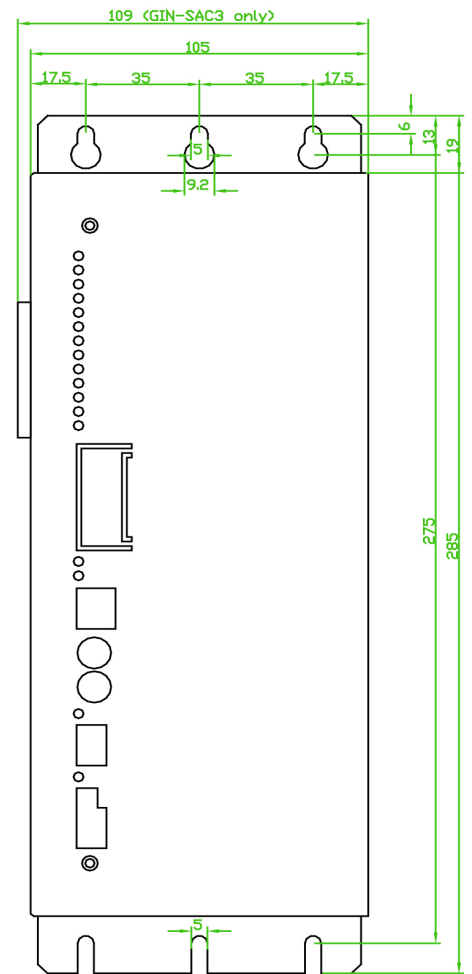

Fig. 4: SAC 16/24A

GIN-SAC3	2.5A
GIN-SAC3	4A/230V
INFO-SAC3	2.5A
INFO-SAC3	4A/230V

GIN-SAC3	5A
INFO-SAC3	5A

GIN-SAC3	16A / 24A
INFO-SAC3	16A / 24A

#### Dimensions of INFO-SAC3

Version	Width x Depth x Height
2.5A	61 x 168 x 285 mm
4A/230V	61 x 168 x 285 mm
5A	76 x 168 x 285 mm
16A	105 x 168 x 285 mm
24A	105 x 168 x 285 mm

#### Dimensions of GIN-SAC3

Version	Width x Depth x Height
2.5A	65 x 168 x 285 mm
4A/230V	65 x 168 x 285 mm
5A	80 x 168 x 285 mm
16A	109 x 168 x 285 mm
24A	109 x 168 x 285 mm

A minimum distance of 10mm must be maintained between the individual servo drives.

**Dimensions of GIN-SAC3x3 / INFO-SAC3x3**

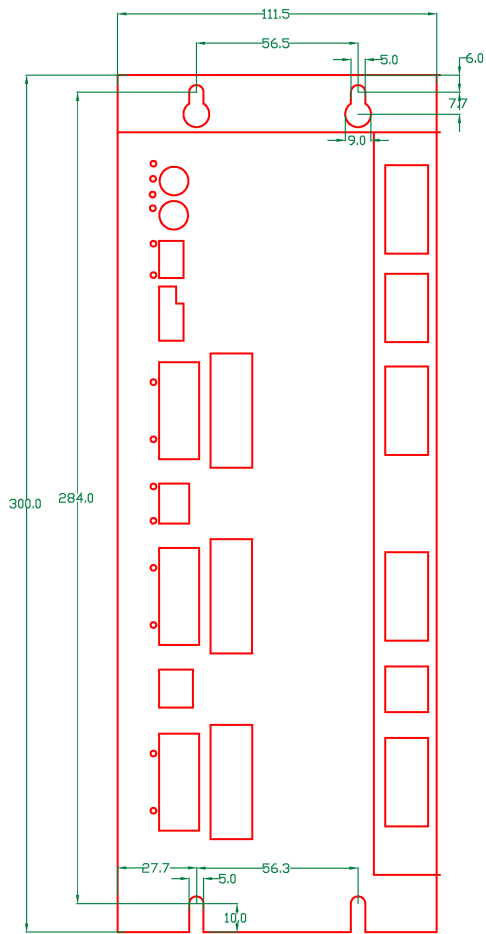

*Fig. 5: SAC3x3*

Depth: 175mm

A minimum distance of 10mm must be maintained between the individual servo drives.

## 3.3 *Installation*

### 3.3.1 *Assembly*

Assembly must be carried out according to the documentation and using suitable tools. The devices must only be assembled when switched off. When carrying out wiring work on the drive, the control cabinet must be secured against reactivation. National accident prevention regulations must be complied with. Electrical installation must be carried out in accordance with national provisions (wire colours, cross-sections, fuses, protective earth connection, etc.).

### 3.3.2 *24V power supply*

#### *Card supply*

A regulated 24V supply with sufficient reserve capacity is recommended for the power supply to the card. The 24V supply must be equipped with a mains filter.

#### *Supply to the safety-related cut-out*

The supply to the safety-related 24V power supply must limit the maximum current to 6A.

The motor may spin out in the event of loss of the 24V power supply to the drive. If this is not permissible, external measures must be taken to prevent the axis from spinning out.

### 3.3.3 *Cabling*

#### *Cabling of the safety-related cut-out*

The energy lines and safety-related 24V power supply must be laid in separate cables for applications with safety-related cut-out of the drive under stop category 0 or 1 as per EN 60204-1 and fault-safe protection against restart as per EN ISO 13849 category 3 for servo controllers. The cable for the safety-related 24V power supply must be designed as follows to avoid tension:

- Use shielded cables
- Apply the shielding on both sides (See Indel wiring guidelines)
- Lay the cables in metallic cable channels or ducts
- Limit the maximum cable length to 100 m

#### *Cabling*

The motor cable must be laid separately from the signal and network cables. Motor cables must not lead over clamps; if necessary, use metallic plug connectors. The shielding must be attached with all-round contact in the pin.

Also see Indel wiring guidelines and INDEL setup guidelines.

#### *Shielded cables*

The resolver and SinCos interface signals are extremely susceptible to interference, meaning that these lines are equipped with a pair-twisted and double shielded cable.

The inc encoder and serial interface, as well as the motor cable, must be shielded cables!

The encoder cables must not be separated in order to get to the control cabinet via clamps. The D-SUB pin of the encoder cables must be screwed into the drive.

The shielding braid of the encoder and motor cables must cover at least 85% of the surface. Shielding braid with higher coverage must be used in environments with increased EMC interference.

Shielding must always be applied on both sides.

The motor cable must be shielded. Please use a four-wire cable with earth conductor.

A shielded cable must be used for the temperature sensor. It must be ensured that the temperature sensor used has sufficient insulation for the motor winding.

**Potential equalisation**

Apply all shielding on both sides. You may need to use a potential compensator in order to avoid unwanted leakage currents over the shielding, particularly in the case of larger distances or different supplies. See “Indel wiring guidelines”.

**Shield rail**

The control cabinet must include a shield rail, to which all shielded cables can be attached. Metallic pins with all-round contact with the shielding are also suitable for cable insertion.

The servo controllers must be assembled on the assembly plate with good conductivity. All shielded cables must be shielded on both sides.

**Plug-in connections**

Interruptions in the resolver and motor cables – when leading them into a cabinet or similar – should be designed with metal plug connections, not clamp connections. This ensures that the cable shielding is not interrupted unnecessarily.

**3.3.4 Other connections****Inputs and outputs**

The additional digital inputs and outputs can only be wired within the control cabinet. If the cabling is longer than 1m, these inputs and outputs must also be equipped with shielding.

**Motor temperature**

The motor temperature can be measured using either a bi-metal switch (T-switch) in the motor or an NTC (MTemp). The bi-metal switch can only be wired with the motor cables. The NTC can only be wired in the resolver cables. (Note insulation class!)



### 3.4 Cooling and ventilation

Sufficient measures and steps must be taken to ensure that the temperature in the control cabinet does not exceed the specified maximum. Fans or air conditioning units must therefore be placed in suitable locations inside the control cabinet.

**Indel accepts no liability for insufficient cooling and the resulting overheating in the control cabinet!  
It is the user's responsibility to comply with the operating and ambient conditions.**

If air conditioning units are being used, it must be ensured that excessively low temperatures do not cause condensation.

Only use well-sealed control cabinets to prevent contaminated ambient air entering the control cabinet.

**Cold air exiting the air conditioning unit must be prevented from blowing directly onto the housing of a servo drive. In unfortunate cases, particularly where humidity is high, this can lead to condensation on the inside of the device.**

#### 3.4.1 Assembly and cooling of SAC3x3 drives

In the SAC3x3, the heat sink is mounted in a free-standing manner at the back of the controller. This allows for assembly of the controller, whereby the heat sink sticks out the back of the control cabinet. This allows for the targeted removal of the power unit heat source from the control cabinet. This reduces the additional temperature increase within the control cabinet caused by the SAC3x3. The SAC3x3 should be installed in this manner wherever possible.

If the heat sink temperature of the SAC3x3 drive exceeds 70°C, the heat sink must be equipped with additional ventilation. The available fan connection, as can be seen in 6 , can be used for this purpose. The connection for the fan is located beneath the SAC3x3, beside pin X100. Any 24V fan can be connected directly to this PWM output. The maximum current carrying capacity is 2A. The fan can be connected using a 2-pole cable jack with 2.54mm contact spacing.

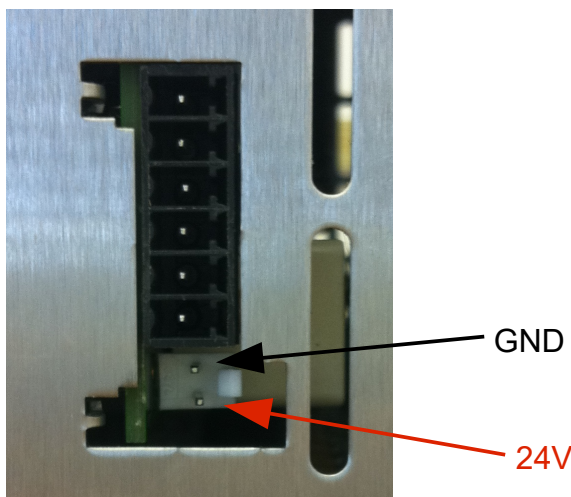

Fig. 6: Fan connection, SAC3x3

### 3.5 Network, mains connection

#### 3.5.1 Network forms

The operation of Indel servo controllers is only permitted on earthed TN, TT networks.

Operation on delta networks (TN-S networks with earthed phase) or IT networks (insulated earth) is not permitted. An isolating transformer must be used for operation on networks other than TN or TT, whereby the secondary-side neutral point must be earthed.

#### 3.5.2 Protective earth connection (PE)

The protective earth must be designed in accordance with EN 61800-5-1:

Cross-section of the outer conductor [mm <sup>2</sup> ]	Minimum cross-section of the corresponding protective earth conductor S <sub>p</sub> [mm <sup>2</sup> ]
$S \leq 16$	S
$16 < S \leq 16$	16
$35 < S$	S/2

Table 1

Protective earth conductors that are not part of a cable must have a minimum cross-section of 4mm<sup>2</sup>.

#### 3.5.3 Mains filter

The power supply must be equipped with a filter. The optimum filter and placement may need to be defined by means of an emission measurement as the emitted interference is dependent upon the motor cable length, among other things. Without correctly dimensioned filters, the product may cause very frequent interference.

### 3.6 ***Parallel connection of the intermediate circuit***

The operation of Indel servo controllers is only permitted on earthed TN, TT networks. Operation on delta networks (earthed phase) or IT networks (insulated earth) is not permitted.

The intermediate circuits of various drives can be connected. However, this is only the case for intermediate circuits with the same voltage and a maximum of 5 drives.

The controllers of the SAC3 drives contain two 0.033 Ohm (4W) resistors, which limit the equalisation currents between the individual drives in the intermediate circuit.

No resistors are present in the intermediate circuit on the SAC3x3 drives. If the intermediate circuits of the SAC3x3 drives are connected, external resistors must be installed to limit equalisation currents.

The intermediate circuits of drives fed in single-phase can only be connected if all drives are connected to the same phase. Otherwise the intermediate circuit voltage will increase and the drives will be destroyed!

### 3.7 ***High-voltage test, insulation resistance test***

Under no circumstances can a high-voltage test or an insulation resistance test be carried out on the mains connection or motor connection of the drives. Otherwise the drive will be destroyed.

### 3.8 ***Residual current circuit breaker***

Only type B residual current circuit breakers (sensitive to universal current) can be used.

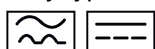

#### ***Further documentation***

Also see Indel wiring guidelines and INDEL setup guidelines.

### 3.8.1 Notes on UL directive

#### **UL fuses and cable cross-sections**

The controller requires a fuse in the supply line. Only use UL-certified fuses and holders. Triggering characteristic “K”.

Controller	fuse A	Safety	Cable cross-section <i>mm<sup>2</sup></i>	<i>AWG</i>
SAC-2.5A	5		1	17
SAC-4A	10		1	17
SAC-5A	10		1	17
SAC-16A	25		6	9
SAC-24A	25		6	9

Manufacturers of UL-certified safety fuses:

- FS Ferraz Shawmut
- Limitron KTK from Bussmann

Only use UL-certified copper wires for 75°C.

### 3.8.2 Motor overload protection

#### **Motor overload protection**

External motor overload protection must be provided by the user.

Additional overload protection is provided for motors by means of temperature sensors in the field winding. The user is responsible for applying this overload protection.

#### **I<sup>2</sup>t cut-out**

The I<sup>2</sup>t cut-out provides additional protection against motor overload. Please see “Drive-Inbetriebnahme-Manual.pdf”

#### **Braking resistance**

The braking resistor must be secured against thermal overload. Voltages of up to 800V can arise on the braking resistor. The braking resistor must be designed for this purpose.

The control of the braking resistor is not designed to be safe.

### **3.9 Maintenance, cleaning, repair**

The Indel servo drives are maintenance-free. Any warranty shall expire if the housing is opened.

Do not submerge or spray the housing. In the event of contamination inside the unit: have it cleaned by the manufacturer.

Repairs can only be carried out by authorised specialist personnel. Any warranty on the part of Indel shall expire in the event of unauthorised intervention.

### **3.10 Transport and storage**

In the case of storage up to 12 months: no restriction.

In the case of storage for more than 12 months, the capacitors must be re-formatted before commissioning the servo drive. To do this, disconnect all electrical connections and feed L1 / L2 for 20 min. at 230V AC ein.

When storing, please consider the effect of the ambient conditions: avoid impermissible stresses such as mechanical load, temperature, moisture, aggressive atmospheres.

## 4 Safety stop

The notes from section 1. Safety notes are binding.

### 4.1 Stop functions as per EN 60204-1:

#### Category 0: Safety stop, safety start lock

Brings the unit to a stop by immediately switching off the energy supply to the machine drives (i.e. uncontrolled stopping)

#### Category 1: Safe stop

Controlled stopping whereby the energy supply to the machine drives is retained in order to bring the unit to a stop; the energy supply is only interrupted when it has come to a stop. E.g. after a set period of time.

#### Category 2: Safe operational stop

A controlled stop whereby the energy supply to the machine drives is retained. The braking ramp and stopping are monitored.

### 4.2 Handling in an emergency

#### Emergency stop

The emergency stop must function in line with either stop category 0 or stop category 1. The selection of the stop category for the emergency stop is dependent upon the results of the risk assessment for the machine. Also see EN ISO 14121-1, EN 13850.

In addition to the stop requirements, the following requirements apply to the emergency stop function:

- it must have priority over all other functions and actions in all operating modes
- the energy supply to the machine drives, which could cause a dangerous situation (or situations) must either be immediately interrupted without causing other dangers (stop category 0) or controlled in such a way that the hazardous movement is stopped as quickly as possible (stop category 1)
- reset must not cause the unit to restart.

#### Emergency stop

An emergency stop should be provided where:

- **protection against direct contact** (e.g. with conductor lines, slip rings, switching devices in electrical operating rooms) will only be achieved through spacing or obstacles or
- there is the possibility of other risks or damage through electrical energy.

An emergency stop is achieved by switching off the corresponding energy supply with **electro-mechanical switching devices**, resulting in stop category 0 for the machine drives connected to this energy supply. If stop category 0 is impermissible for a machine, it may be necessary for other measures to be taken, e.g. protection against direct touching, so that an emergency stop is not necessary. Also see EN 60204.

### 4.3 Functional principle of safety stop STO

The safety stop on the Indel servo drives is implemented using a “safety pulse inhibitor”.

#### Block wiring diagrams for safety pulse inhibitor

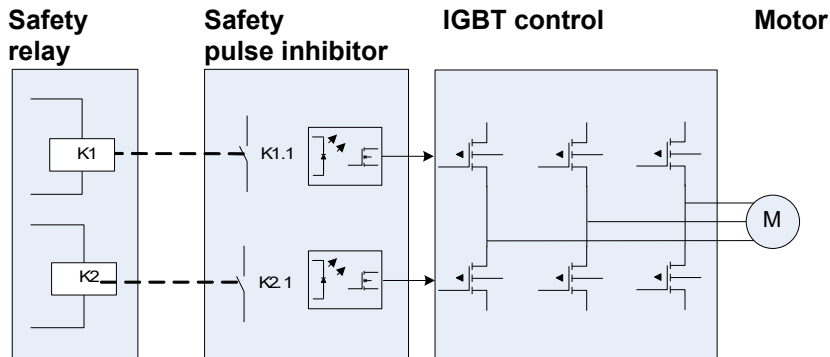

Fig. 7: Functional principle of safety stop

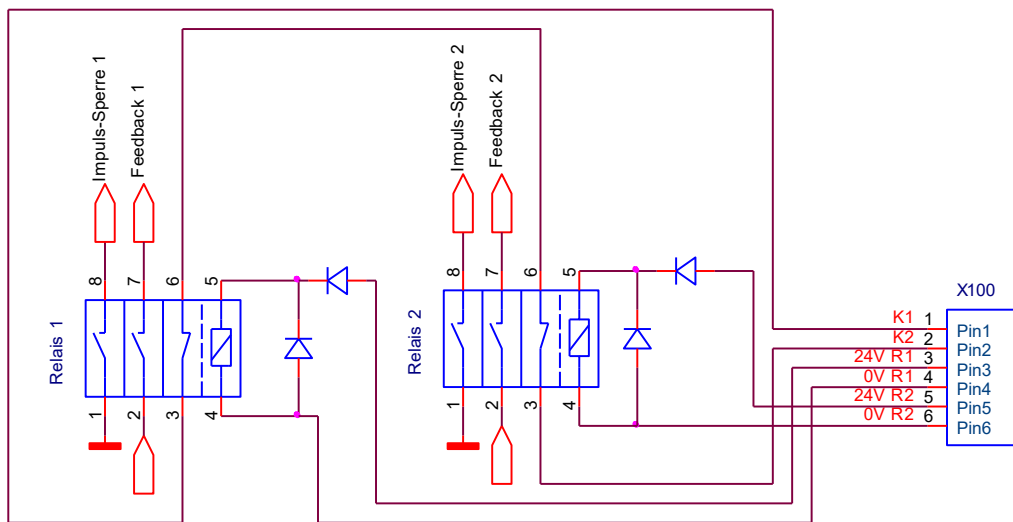

Fig. 8: Safety stop

Both pulse inhibitors each have an effect on the upper or lower IGBTs.

The condition of the two safety relays can be viewed via invisible variables. All contacts for relay 1 and relay 2 are positively driven.

The condition of the two safety relays must be monitored by the user software. If an impermissible condition is identified, the software must disconnect the power supply (main contactor or motor contactor)

**Cross-circuits between 24V\_R1 and 24\_R2 must be excluded.**

#### Pin assignment X100

1	K1	Auxiliary contact
2	K2	Auxiliary contact
3	24V_R1	Supply relay 1
4	0V_R1	Gnd Relais 1
5	24V_R2	Supply relay 2
6	0V_R2	Gnd Relais 2

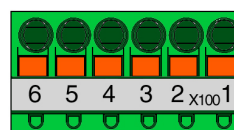

Fig. 9: Pin X100

## 4.4 Diagnostic functions

### 4.4.1 Diagnostic function in the servo drive

The two auxiliary contacts for the safety relay are evaluated in the servo drive. The two contacts can only have a different condition for max. 50ms.

In the case of different switch positions, the controller will be deactivated and a corresponding error will be displayed.

An error is issued if the drive is activated without the safety relay being activated.

Suitable software must be used to interrupt the energy supply in the fieldbus controller.

### 4.4.2 Diagnostic function in the fieldbus controller

#### *Testing controller release*

Testing of the controller release must be implemented in the fieldbus controller:

- Switch off the two relays, R1 and R2, then activate the controller and try to move the motor.
- Switch on relay R1 and try to move the motor (alternative: implant idle current, test with current measurement).
- Switch on relay R2 and try to move the motor (alternative: implant idle current, test with current measurement).

The plausibility of the auxiliary contacts of R1 and R2 must also be checked during the testing of the controller release.

**If the motor is able to be moved during the controller release testing, or the plausibility of the auxiliary contacts displays an error, there is a defect in the safety function.**

**In this case, the servo drive must not be commissioned!  
This must be ensured using the application software.**



## 4.5 Reaction times

### Reaction times for safety function requests

The reaction time of the safety function must be considered within the entire system:

- Response time of the sensors such as light curtain, limit switch, etc.
- Delay in the inputs on the safety switching device
- Internal processing time of the safety switching device
- Delay time of the external enabler on the SAC drive
- Time delay for STO category 1
- Delay time of the safety relay on the SAC drive
- Delay time caused by further assembly groups

Reaction times when requesting the safety function			
Delay time of sensor	ms	...	$t_{SF}$
Delay time of input stage of the safety switching device	ms	...	$t_{INP}$
Processing time in the safety switching device	ms	...	$t_{SSD}$
Delay time for STO (depending on application)	ms	...	$t_D$
De-energisation of the safety relays	ms	15	$t_{SIS}$
Further delay times	ms	...	$t_N$

$$\text{Time to stop} = t_{SF} + t_{INP} + t_{SSD} + t_D + t_{SIF} + t_N$$

### Reaction times in the event of a fault

The diagnostic functions in the servo drive and in the fieldbus controller can switch off the energy supply with unsafe outputs.

Reaction times in the event of a fault			
Delay time of input stage of the auxiliary contacts	ms	0.25	$t_{CON}$
Reaction time of servo drive (worst case: 8kHz)	ms	0.13	$t_{SD}$
Delay when comparing both contacts	ms	50	$t_C$
Fieldbus transmission (worst case: 1kHz)	ms	1	$t_{FB}$
Processing time in the fieldbus controller (worst case)	ms	1	$t_{FC}$
Delay time for STO (depending on application)	ms	...	$t_D$
Delay time of digital output	ms	0.2	$t_{OUT}$
De-energisation of the contactor contacts	ms	...	$t_{PS}$

$$\text{Time to stop} = t_{CON} + t_{SD} + t_C + t_{FB} + t_{FC} + t_{FB} + t_{OUT} + t_D + t_{PS}$$

## 5 Pin assignment

All pins on the drives must only be plugged in or unplugged when the unit is switched off. Once the energy supply has been switched off, residual voltage may remain in the unit for a further 5 minutes!

Motor, mains, ballast and intermediate circuit pins carry voltages of more than 50V.

### 5.1 Pin assignment of SAC2, SAC3 drives

#### 5.1.1 Pin arrangement of SAC2, SAC3 drives

SAC 2.5A, SAC 4A/230V, SAC 5A

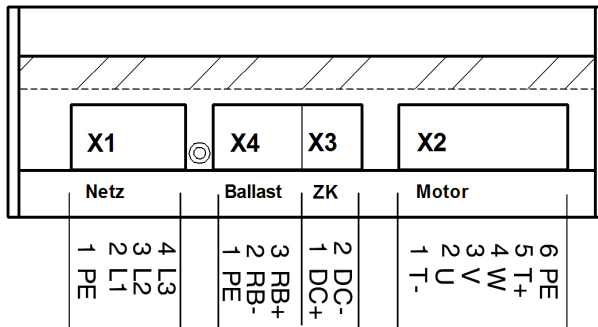

Fig. 10: Pin assignment 1

#### Pin assignment of SAC 16A, SAC 24A

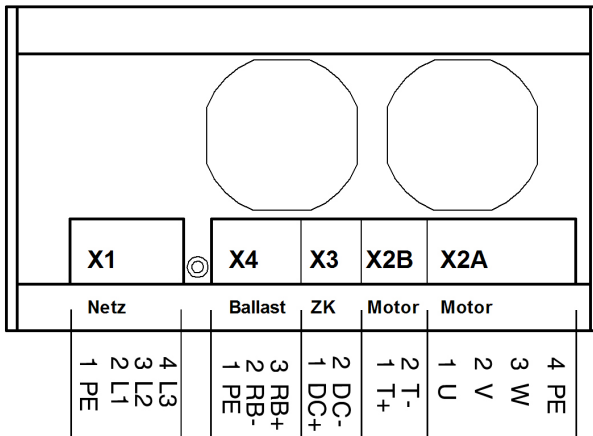

Fig. 11: Pin assignment 2

## 5.1.2 Motors, energy supply of SAC drives

### SAC 2.5A, SAC 4A/230V, SAC 5A

<b>X1</b> Mains	1	I	PE	Earth
	2	I	L1	Phase 1
	3	I	L2	Phase 2
	4	I	L3	Phase 3
<b>X2</b> Motor	1	I	T -	Temperature switch (bi-metal)
	2	O	U	Winding U
	3	O	V	Winding V
	4	O	W	Winding W
	5	I	T +	Open Overheating Closed Ok
	6	O	PE	Earth
<b>X3</b> Intermediate circuit $U_{CC}$	1	O	DC +	Intermediate circuit $U_{CC} +$
	2	O	DC -	Intermediate circuit $U_{CC} -$
<b>X4</b> Ballast resistance	1	I	PE	Earth
	2	I	RB -	Ballast resistance -
	3	I	RB +	Ballast resistance + (corresponds to $U_{CC} +$ )

### SAC 16A, SAC 24A

<b>X1</b> Mains	1	I	PE	Earth
	2	I	L1	Phase 1
	3	I	L2	Phase 2
	4	I	L3	Phase 3
<b>X2A</b> Motor	1	O	U	Winding U
	2	O	V	Winding V
	3	O	W	Winding W
	4	O	PE	Earth
<b>X2B</b> Temperature sensor	1	I	T -	Temperature switch (bi-metal)
	2	I	T +	Open Overheating Closed Ok
<b>X3</b> Intermediate circuit $U_{CC}$	1	O	DC +	Intermediate circuit $U_{CC} +$
	2	O	DC -	Intermediate circuit $U_{CC} -$
<b>X4</b> Ballast resistance	1	I	PE	Earth
	2	I	RB -	Ballast resistance -
	3	I	RB +	Ballast resistance + (corresponds to $U_{CC} +$ )

O: Output  
I: Input

### 5.1.3 Supply, encoder connections of the SAC drives

<b>X15</b> Supply	1	I	24V	24V supply
	2	I	0V	Ground
	3	I	+ En	External enabler input + (24V DC)
	4	I	- EN	External enabler input - (ground)
	5	O	+ O	Output 1
	6	O	- O	Output 1
	7	O	+ Act	Output 0 (active)
	8	O	- Act	Output 0

<b>X100</b> Safety Also see: section 4.3	1	O	K1	Auxiliary contact
	2	O	K2	Auxiliary contact
	3	I	24V_R1	Supply relay 1
	4	I	0V_R1	Gnd Relais 1
	5	I	24V_R2	Supply relay 2
	6	I	0V_R2	Gnd Relais 2

**X12**  
Incremental encoder  
D-sub 9-pole  
Female

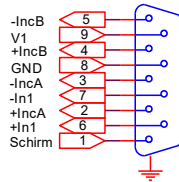

V1 = 5V DC

**X13**  
Resolver  
D-sub 9-pole  
Female

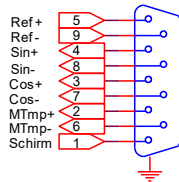

**X14A**  
SinCos Interface  
D-sub, 15-pole  
Female

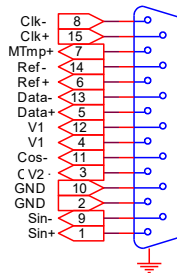

V1 = 5 VDC  
V2 = 5 VDC or 10 VDC

In the case of all SAC3 drives, there is a jumper on the side of the housing; this jumper allows the voltage at V2 to be set to 5 VDC or to 10 VDC.

**Important: For the 5V supply, use pin 12; for the 10V supply, use pin 4! See page 40**

**X14B**  
SinCos Interface  
D-sub 9-pole  
Female

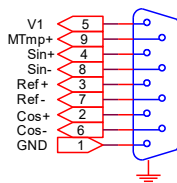

V1 = 5 VDC

Interruptions in the resolver and motor cables – when leading them into a cabinet or similar – should

be designed with metal plug connections, not clamp connections.

### 5.1.4 Digital IOs of SAC drives

External enabler:

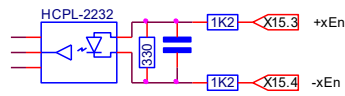

Incremental encoder inputs:  
A, B, zero-pulse

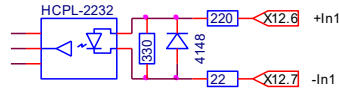

Output 0 (active):  
Output 1

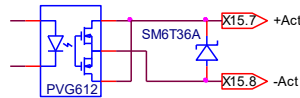

### 5.1.5 Serial interface of the SAC drives

#### X5, SIO

SAC-Drive	SAC-Drive	Cable	PC (9-pole pin)
Pin 1	nc		nc Pin 1
Pin 2	Rx	↔	Rx Pin 2
Pin 3	Tx	↔	Tx Pin 3
Pin 4	DTR	↔	DTR Pin 4
Pin 5	Gnd	↔	Gnd Pin 5
Pin 6	DSR	↔	DSR Pin 6
Pin 7	nc		nc Pin 7
Pin 8	nc		nc Pin 8
Pin 9	nc		nc Pin 9
Housing	Shield	↔	Shield Housing

### 5.2 Pin assignment of SAC3x3 drives

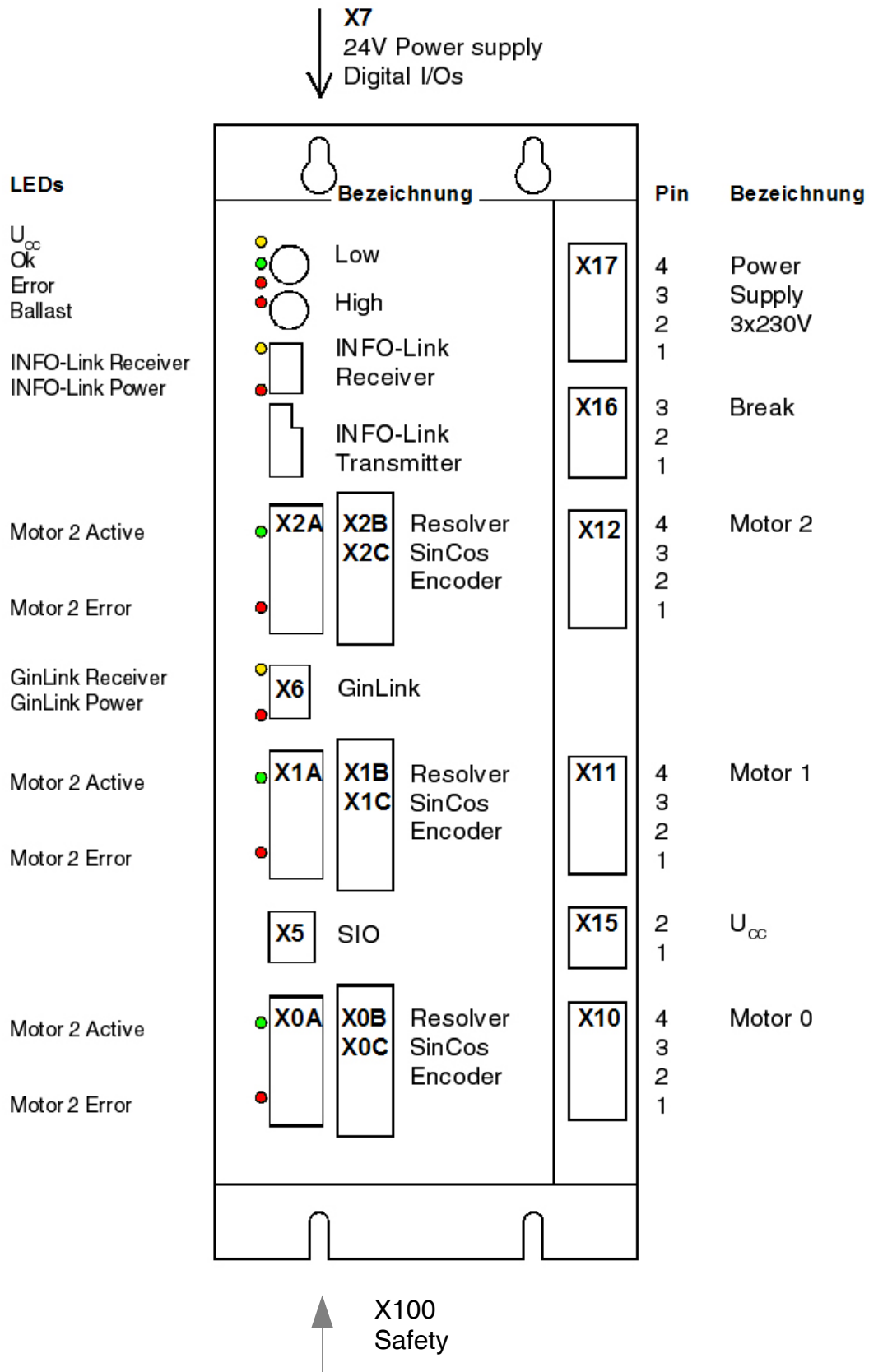

## 5.2.1 Motors, energy supply of SAC3x3 drives

<b>X10</b> Motor 0	1	I	PE	Earth
	2	O	U	Winding U
	3	O	V	Winding V
	4	O	W	Winding W
<b>X11</b> Motor 1	1	I	PE	Earth
	2	O	U	Winding U
	3	O	V	Winding V
	4	O	W	Winding W
<b>X12</b> Motor 2	1	I	PE	Earth
	2	O	U	Winding U
	3	O	V	Winding V
	4	O	W	Winding W
<b>X15</b> Intermediate circuit U <sub>CC</sub>	1	O	DC +	Intermediate circuit U <sub>CC</sub> +
	2	O	DC -	Intermediate circuit U <sub>CC</sub> -
<b>X16</b> Ballast resistance	1	I	PE	Earth
	2	I	RB -	Ballast resistance -
	3	I	RB +	Ballast resistance + (corresponds to U <sub>CC</sub> +)
<b>X17</b> Mains	1	I	PE	Earth
	2	I	L1	Phase 1
	3	I	L2	Phase 2
	4	I	L3	Phase 3
<b>X100</b> Safety Also see: section 4.3	1	O	K1	Auxiliary contact
	2	O	K2	Auxiliary contact
	3	I	24V_R1	Supply relay 1
	4	I	0V_R1	Gnd Relais 1
	5	I	24V_R2	Supply relay 2
	6	I	0V_R2	Gnd Relais 2

O: Output  
I: Input

### 5.2.2 Supply, encoder connections of SAC3x3 drives

<b>X7</b>				
Supply	1	I	24V	24V supply
	2	I	0V	Ground
	3	I	IN 3	Input 3
	4	I	IN 2	Input 2
	5	I	IN 1	Input 1
	6	I	Ext En	External enabler input (24VDC)
	7	O	OUT 3	Output 3
	8	O	OUT 2	Output 2
	9	O	OUT 1	Output 1
	10	O	Active	Drive active / output 0
	11	I	24V Dout	Supply of the 24V outputs
	12	I	0V Dout	Ground for 24V outputs

**X0A, X1A, X2A**  
 Resolver  
 D-sub 9-pole  
 Female

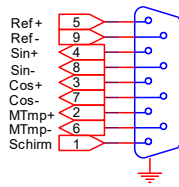

**X0C, X1C, X2C**  
 SinCos Interface  
 D-sub, 15-pole  
 Female

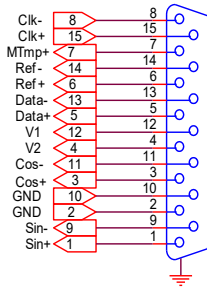

V1 = 5V DC  
 V2 = 10V DC

### 5.2.3 Digital IOs of SAC3x3 drives

Digital Outputs:

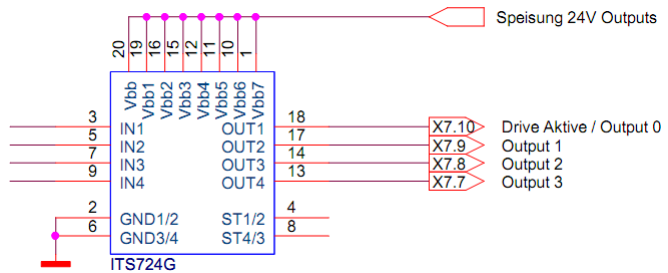

In the motor conFig.uration file, the “Axis active” flag and the “I cmd” flag can be assigned to the outputs.

Digital inputs / external enabler:

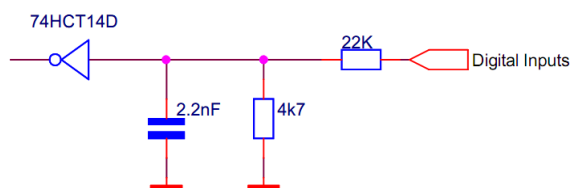



## 5.2.4 Incremental encoder

The SAC3x3 no longer offers an independent interface for incremental encoders. However, these can be connected to the SinCos or absolute feedback system interface and operated from there. We recommend that they be connected to the absolute feedback interface as it allows considerably higher sampling rates to be achieved than with the SinCos interface.

### *Incremental encoder to SinCos inputs*

<b>X.A, X.C</b>	+IncA = Cos+
Instead of SinCos	-IncA = Cos-
encoders, incremental	+IncB = Sin+
encoders	
Incremental encoder	-IncB = Sin-
be used	+Ref = Ref+
	-Ref = Ref-

### *Incremental encoder to absolute feedback inputs*

Incremental encoders can	+IncA = Clk+
also	-IncA = Clk-
be connected to the inputs	
for the	+IncB = Data+
absolute feedback	-IncB = Data-
system.	
	+Ref = Ref+
	-Ref = Ref-

This allows you to achieve considerably higher signal frequencies; see: section 3.1 Technical details for Indel servo controllers, sub-section: Incremental encoder

Interruptions in the resolver and motor cables – when leading them into a cabinet or similar – should be designed with metal plug connections, not clamp connections.

The external enabler has an effect on all axes at once.

### Single-ended incremental encoders

Additional level adjustment is required if single-ended incremental encoders are being used. The connection must be made to the absolute feedback interface. **However, we generally recommend that you use incremental encoders with a RS422 interface as per the current industry standard.**

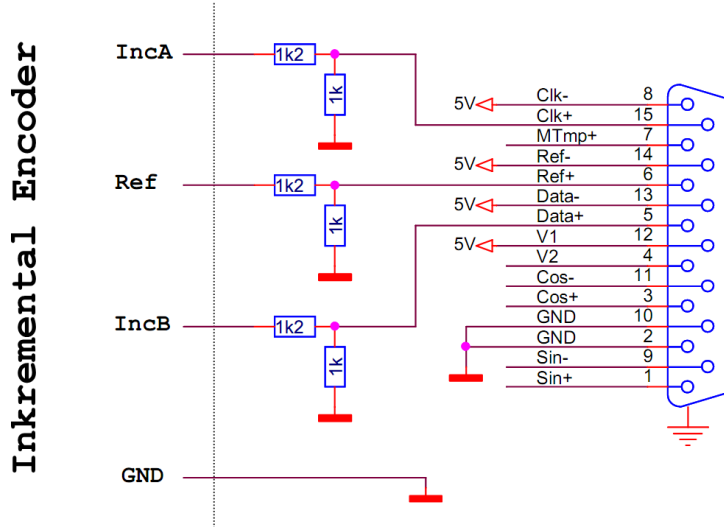

Fig. 12: Connection example for 24V single-ended incremental encoder

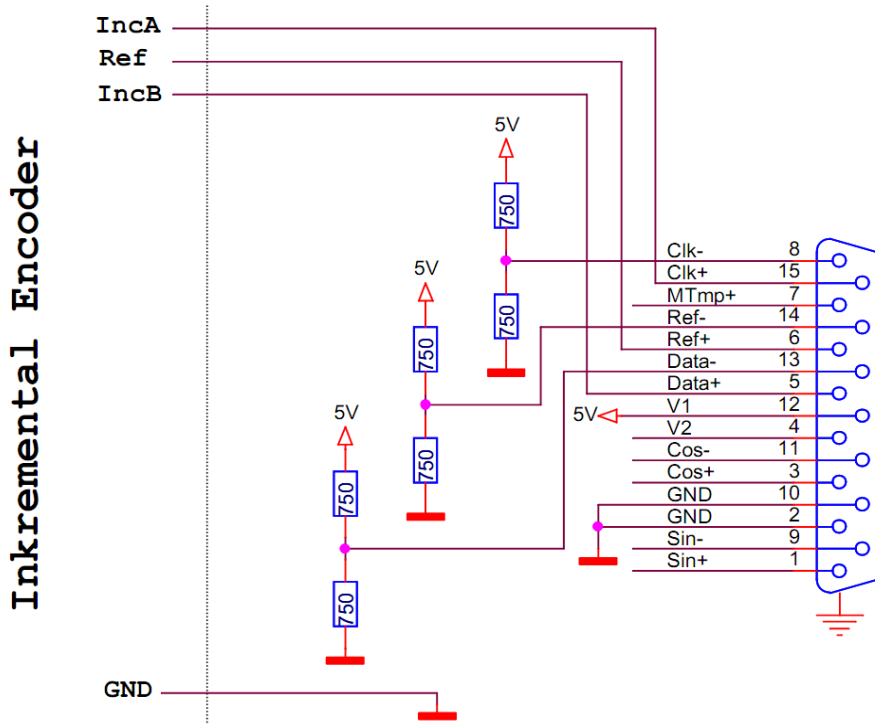

Fig. 13: Connection example for 5V single-ended incremental encoder

### 5.2.5 Serial interface of SAC3x3 drives

X5, SIO	RJ-45	SAC3x3		Cable	PC (9-pole pin)	
Norm	SAC3x3					
Pin 1	-				nc	Pin 1
Pin 2	Pin 1	Tx	Output	→	Rx	Pin 2
Pin 3	Pin 2	Rx	Input	←	Tx	Pin 3
Pin 4	Pin 3	DTR	Output	↗ ↘	DTR	Pin 4
Pin 5	Pin 4	DSR	Input	↖ ↙	DSR	Pin 6
Pin 6	Pin 5	Gnd		↔	Gnd	Pin 5
Pin 7	Pin 6	nc			nc	Pin 7
Pin 8	-				nc	Pin 8
					nc	Pin 9
					Shield	Housing

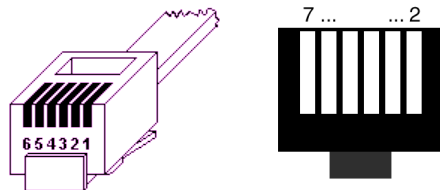
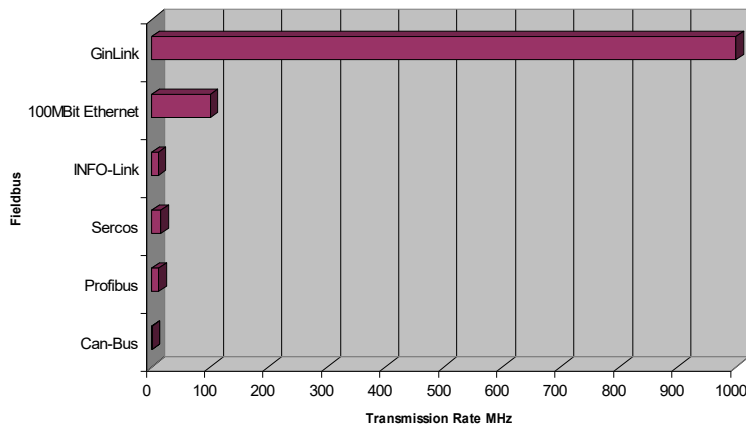

Fig. 14: RJ pin

## 6 Fieldbus systems

### 6.1 GinLink



- GHz fieldbus, max. 32kHz cycle time
- Ethernet, up to 100m segment length
- GinLink frames packed into Ethernet frames
- Standard Ethernet frames: PowerLink, EtherCat cameras
- Deterministic transmission
- Jitter <70ns

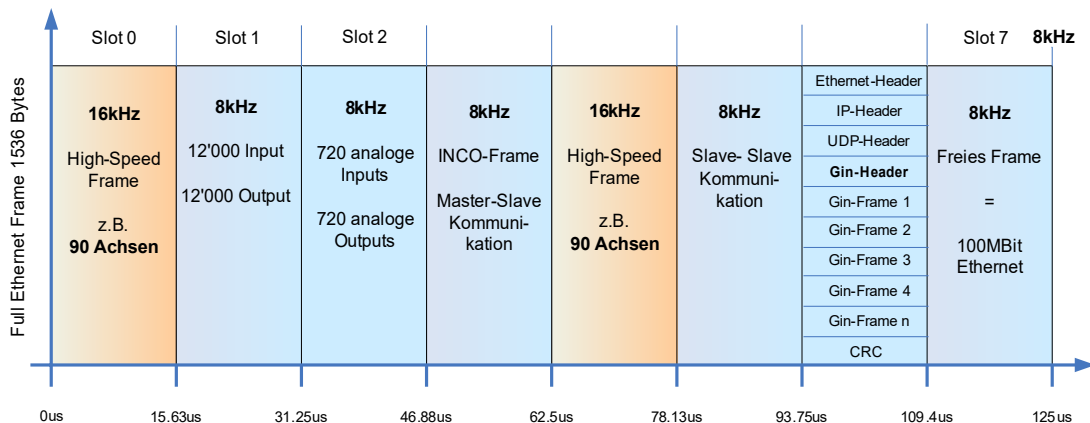

	Number	Sampling-Rate	Data
Axes	90	16kHz	4 x 32 Bit
Digital Inputs	12000	8kHz	1 Bit
Digital outputs	12000	8kHz	1 Bit
Analogue inputs	720	8kHz	16 Bit
Analog Outputs	720	8kHz	16 Bit
Communication			
Slave to Master	1	8kHz	11.5 MByte/s
Slave to Slave	1	8kHz	11.5 MByte/s
Standard Ethernet frames	2	8kHz	23.0 MByte/s

## 6.2 Info-Link

### Addressing

S1,S2 (HI,LO) Addr. (Y0,0X)	Axis (Channel)	with 2nd feedback system (Channel)
0x00 ... 0x03	0 ... 3	
0x10 ... 0x13	4 ... 7	
...		
0x70 ... 0x73	28 ... 31	
0x80, 0x82	0, 2	1, 3
0x90, 0x92	4, 6	5, 7
...		
0xF0, 0xF2	28, 30	29, 31

A second feedback system (e.g. incremental encoder) can be integrated directly into the control algorithm. If 0x80 is added to the current axis number (increase rotary switch Y0 by 8), the second feedback system registers on the next channel number each time.

Only even addresses are permitted for the controller in this regard, so that the inc encoder lands on an uneven address.

### LEDs on the receiver module

- Power (red) +5V supply
- Rec (yellow) INFO-link receiver-signal OK
- Rec (yellow) flashing yellow LED: INFO-link diagnosis switched on.

### LEDs

The function of the other LEDs on the front plate are described from page 10 onwards.

### Jumper

The jumpers influence the brightness of the transmitting LEDs, and therefore the segment length of the fibre cable to the next card.

### Segment length Jumper position

0 ... 10 m	no jumper
8 ... 30 m	>10 m
20 ... 50 m	>30 m

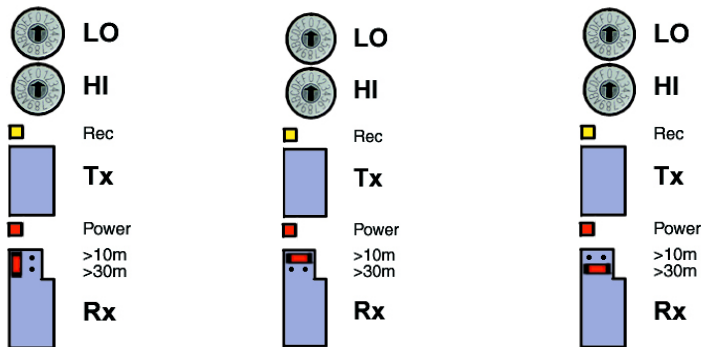

Fig. 15: No jumper, 10m jumper, 30m jumper

## 7 Status LEDs

### 7.1 SAC3 indicator LEDs

**Active**

Motor control active (Out 0)  
 External release present (Ext En, INP-0) Output stage ON, motor under current and position control on active or simulation. If an error occurs, the controller abandons its active status.

**Output**

Current reduction mode active (Out 1)  
 In this mode of operation, the controller limits the maximum current to IRED.

**External enabler**

External controller release (INPUT 0)  
 Locks the output stage using hardware, i.e. the controller cannot be switched to active without external release. INP-0 can be integrated into the emergency stop circuit.

**Input**

Free input (INPUT 1)  
 Free 5V input. (See software manual)

**Inc A, IncB**

Encoder track A (INPUT 2)  
 Encoder track B (INPUT 3)  
 Set up as encoder input A as standard (additional measuring wheel).  
 5V level or RS 422 interface

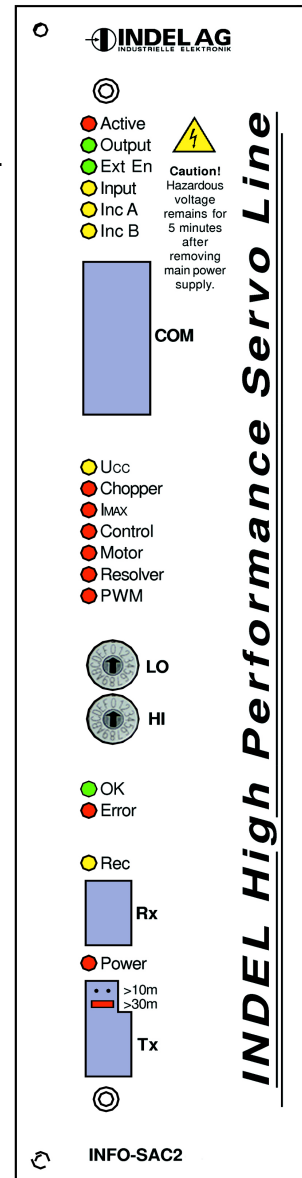

Fig. 16: Status LEDs of SAC drives

## 7.2 SAC3 error LEDs

The SAC3x3 drives have one error LED per axis. All error messages and warnings are displayed using this LED.

### Blink-Code

By lighting up or flashing slowly/quickly, the LEDs display the status of various functions of the controller. The following applies to the following sketch:

E = Error (delete error from software: Inactive, Accept Error, Active)  
 W = Warning

Please use the programme "ACS-Show" as an additional aid for verifying the error.

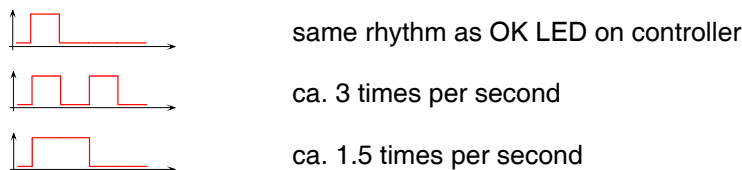

### U<sub>CC</sub> LED *intermediate circuit voltage (565 VDC)* (also see Modulation, PWM LED)

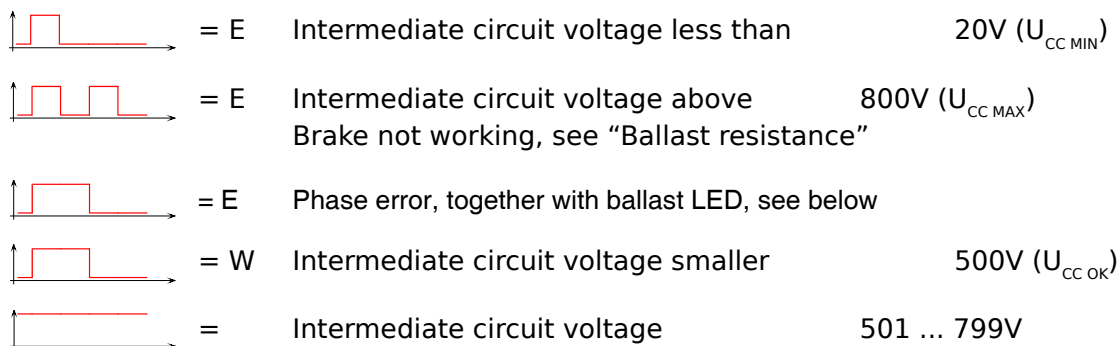

**Ballast LED:** *Ballast resistance*  
 Dimming = Ballast resistance is being switched on and off (PWM output)

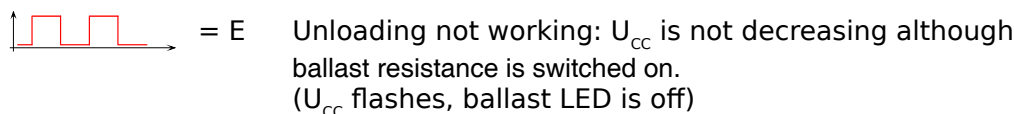

### Possible causes

- No ballast resistance connected
- External supply by controller connected in parallel (U<sub>CC</sub> bridged)

### Ballast and U<sub>CC</sub> LED *phase error*



### I<sub>MAX</sub> LED: *Motor current*

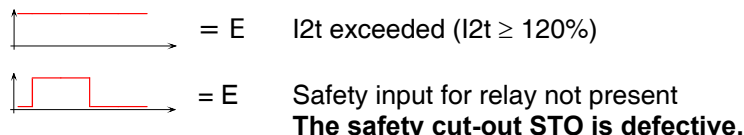

**The drive can no longer be used!**



= W

I<sub>2t</sub> exceeded, motor current is limited to I<sub>RATED</sub>  
( I<sub>2t</sub> = 100 ... 119%)



= W

I<sub>MAX</sub> reached; if the controller is being operated in current limiting mode, this warning appears if I<sub>RED</sub> is reached.

**Control LED:**

**Temperature output stage**

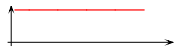

= E

Output stage overheated (from 80°C)



= W

Output stage hot (from 75° C)

**Motor LED:**

**Overheating, short-circuiting**

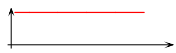

= E

- Motor short-circuit or output stage defective  
- Motor overloaded or blocked (too large a load with too large a starting current). Overcurrent time exceeded



= E

Motor temperature switch engaged for more than 10s



= W

Motor temperature switch engaged

**Resolver LED:**

**Resolver, SinCos interface**

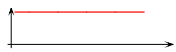

= E

Resolver connection defective or not correct. This error also occurs if the rotor is turning whilst the axis is switched to active.

Signals from SinCos encoder defective or not correct. Common causes of encoder errors:

- Signal too low due to soiled gauges.  
The lower / upper limit for Sin2Cos2 is engaged.
- Too large a distance between gauge and sensor

In the case of axes with auto-commutation: the error “Current Offset Failure” also appears (PWM LED lights up) if a resolver or SinCos error occurs and the axis is to be re-activated. The reason is as follows: in the case of an encoder error, the controller loses the position of the field and therefore needs to be re-commutated.

The variable “Resolver.Sin2Cos2” or “SinCos.Sin2Cos2” can be used to check the quality of the encoder signals. As standard, this value must be between 40 ... 80 for resolvers and between 20 ... 80 for SinCos encoders.

**PWM LED:**

**Auto-commutation**

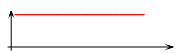

= E

Current offset too large (test before active), to little leeway in auto-commutation. Auto-commutation not carried out



**PWM LED:**

**Modulation**

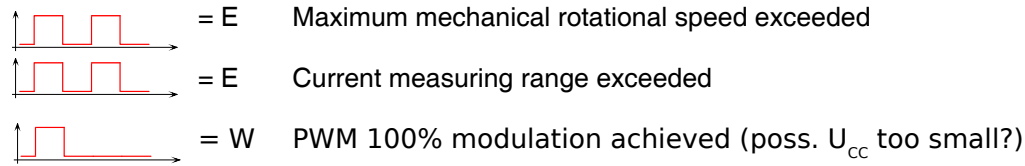

The PWM LED will begin to flash if the motor is operated at high speed.  $U_{cc}$  is out-modulated, i.e. the full intermediate circuit voltage is located in the motor. This is a permissible operating mode.

In the case of high power (current) and high rotational speed, the intermediate circuit voltage decreases and the UCC LED and the PWM LED start to flash. The controller can be operated on a continuous basis in this state.

Only when the controller exceeds the maximum number of permissible path errors (incremental, tow error), is the load limit reached and does the controller go into error.

**Important!**

If the maximum rotational speed cannot be achieved because path errors or tow errors occur, whilst the UCC LED flashes, the following causes must be checked:

- Rating of power supply network (400V) too low. Dimensions of transformer too small or ohm rating of transformer too high. Check cable length and cross-section of the supply cable.
- Motor overloaded

**Remedial action:**

- Use additional windings on the transformer to increase the intermediate circuit voltage; note UMAX!
- If there are several controllers, connect the intermediate circuits in parallel.

**OK, error LED: CPU OK, controller active**

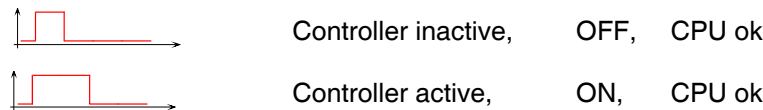

**Error LED:**

**External enabler, software error**

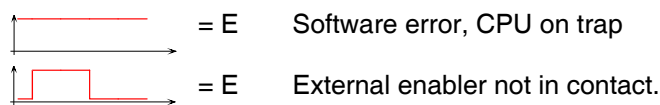

**Error, control LED:**

**Incorrect controller parameters**

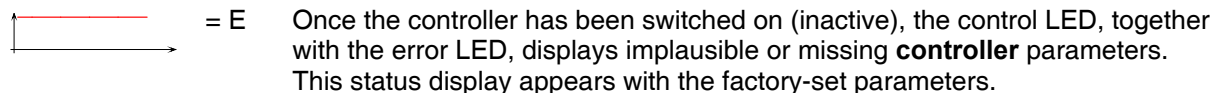

**Error, motor LED:**

**Incorrect motor parameters**

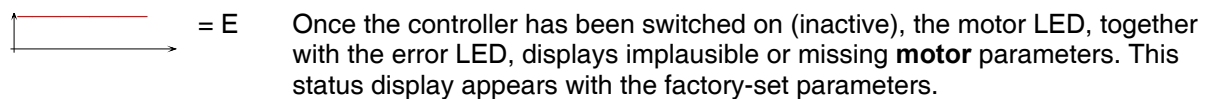

**RAM error**

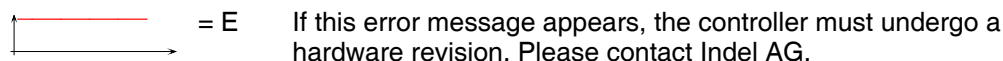

### 7.3 Emergency system

If an error occurs when burning the motor parameters and the flash prom is destroyed, the drive can still be started within the emergency system.

In order to be able to start the drive in the emergency system, a short-circuit plug must be connected to the serial interface (front plate). Flash PROM burning is supported in the emergency system.

Connections:	Signals Pin	SAC2/3 D-SUB 9-pol.	SAC3x3 RJ-45
	RxD, TxD	2, 3	1, 2
	DSR, DTR	6, 4	3, 4

Once the controller has been started, the short-circuit plug can be removed and the serial cable plugged back into the PC.

### 7.4 Error messages

Stop, deactivated	0x0000'0001
Ucc below Ucc min	0x0000'0002
Ucc above Ucc max	0x0000'0004
I2t exceeded > 120%	0x0000'0008
Output stage overheated (80°C)	0x0000'0010
Motor temp exceeded	0x0000'0020
Motor short-circuit	0x0000'0040
Resolver SinCos error	0x0000'0080
Maximum rotational speed exceeded	0x0000'0100
Safety relay not switched on	0x0000'0200
Auto-commutation error	0x0000'0400
Power end stop reached	0x0000'0800
Phase error	0x0000'1000
PWM watchdog: Interrupt overrun	0x0000'2000
missing External Enable	0x0000'4000
missing (Motor) conFig.uration	0x0000'8000
Fieldbus watchdog	0x0001'0000

### 7.5 Warnings

Ucc below Ucc ok	0x0000'0001
Ucc is set up and OK	0x0000'0002
Warning Iq reached	0x0000'0004 1)
Warning output stage hot (75°C)	0x0000'0010
Warning I2t exceeded	0x0000'0020
Motor temp exceeded	0x0000'0040
100% modulation exceeded	0x0000'0080
Warning unloading time exceeded	0x0000'0100

1) This warning appears when the safety relay is not switched on.

## 8 Standards

The following standards have been applied:

2014/35/EU Low voltage directive  
2014/30/EU EMC directive  
2011/65/EU RoHS directive  
2006/42/EG Machinery directive

EN 60204-1: 2006

Safety of machinery – Electrical equipment of machines

Part 1: General requirements, safety-related cut-out under stop category 1 and securing protection against restarting

EN 50178: 1997

Electronic equipment for use in power installations

EN ISO 13849-1

Safety of machinery – Safety-related parts of control systems

Part 1: General principles for design

EN ISO 13849-2: 2003

Safety of machinery – Safety-related parts of control systems

Part 2: Validation

EN 61508: 2002

Functional safety of electrical/electronic/programmable electronic safety-related systems SIL 2

EN 61000-6-2: 2001

Electromagnetic compatibility (EMC) Generic standards Immunity for industrial environments

EN 61000-6-4: 2007

Electromagnetic compatibility (EMC) Generic standards Emission standard for industrial environments

IEC 68-2-6

Environmental testing - vibration

IEC 68-2-29

Environmental testing – bump

EN 1088

Safety of machinery – Interlocking devices associated with guards – Principles for design and selection

EN 61800-5-1: 2007

Adjustable speed electrical power drive systems – Part 5-1: Safety requirements – electrical, thermal and energy

EN 61800-5-2: 2007

Adjustable speed electrical power drive systems – Part 5-2: Safety requirements – functional

EN ISO 12100-1: 2003

Safety of machinery – Basic concepts, general principles for design –

Part 1: Basic terminology, methodology

EN ISO 12100-2: 2003

Safety of machinery – Basic concepts, general principles for design

Part 2: Technical principles

EN ISO 14121-1:2007  
Safety of machinery – Risk assessment  
Part 1: Principles

EN 62061: 2005  
Safety of machinery – Functional safety of safety-related electrical, electronic and programmable  
electronic control systems

## **9 Sales and service**

### **9.1 *Manufacturer***

Indel AG  
Tuefiwis 26  
CH-8332 Russikon  
Switzerland

[info@indel.ch](mailto:info@indel.ch)  
[www.indel.ch](http://www.indel.ch)

Tel. +41 44 956 20 00

### **9.2 *Disposal***

The Indel servo drives are made of various materials:  
Steel housing, aluminium heat sinks, electronic boards

The individual components must be disposed of properly. All Indo servo drives can be returned to Indel AG for proper disposal. The sender shall bear the costs of transport.

## **10 Further documentation**

### **10.1 *Handbooks***

Drive-Inbetriebnahme-Manual.pdf  
Hardware-Manual-Motion-Boards.pdf  
Hardware-Manual-SAC3.pdf  
Verdrahtungsrichtlinie.pdf  
Aufbauanleitung.pdf

## 10.2 Type certificate for SAC3 drives

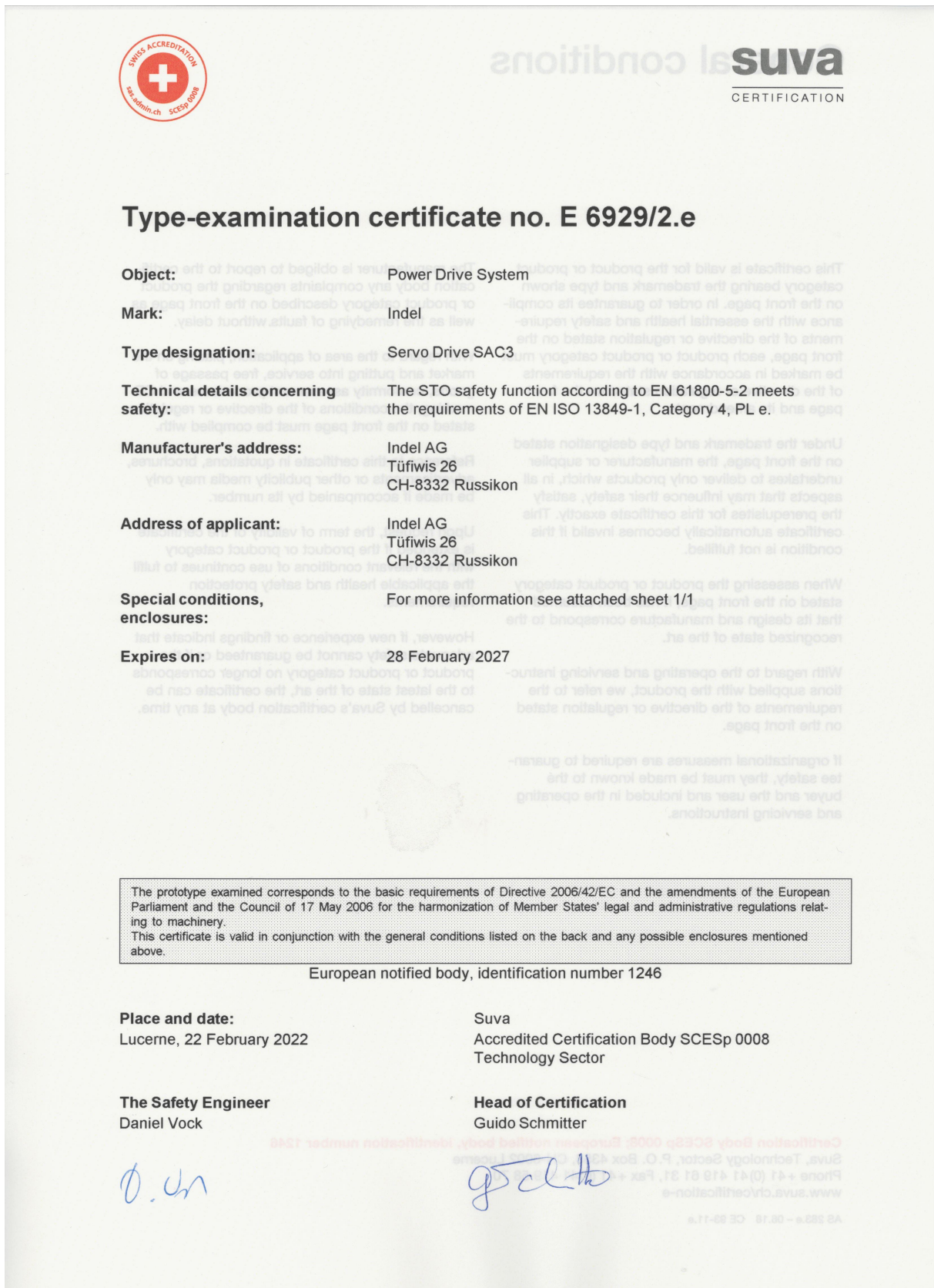

**SWISS ACCREDITATION**  
 www.admin.ch SCESp 0008

**suva**  
 CERTIFICATION

### Type-examination certificate no. E 6929/2.e

**Object:** Power Drive System

**Mark:** Indel

**Type designation:** Servo Drive SAC3

**Technical details concerning safety:** The STO safety function according to EN 61800-5-2 meets the requirements of EN ISO 13849-1, Category 4, PL e.

**Manufacturer's address:** Indel AG  
 Tüfiwis 26  
 CH-8332 Russikon

**Address of applicant:** Indel AG  
 Tüfiwis 26  
 CH-8332 Russikon

**Special conditions, enclosures:** For more information see attached sheet 1/1

**Expires on:** 28 February 2027

The prototype examined corresponds to the basic requirements of Directive 2006/42/EC and the amendments of the European Parliament and the Council of 17 May 2006 for the harmonization of Member States' legal and administrative regulations relating to machinery.  
 This certificate is valid in conjunction with the general conditions listed on the back and any possible enclosures mentioned above.

European notified body, identification number 1246

**Place and date:** Lucerne, 22 February 2022

**The Safety Engineer:** Daniel Vock

**Head of Certification:** Guido Schmitter

Swiss Accreditation Body SCESp 0008, Technology Sector, P.O. Box 458, CH-3000 Bern, Switzerland  
 Phone +41 (0)41 419 81 31, Fax +41 (0)41 419 81 32, www.suva.ch/certification-e

Fig. 17: Type certificate, SAC3 drives

### **10.3 Declaration of conformity**

The current EC declaration of conformity can be found here:

<https://indel.ch/en/documentation#conformity>

## 11 Appendices (informative)

All appendices are purely informative and are non-binding.

### 11.1 Requirements for safety switching devices

The safety switching device must at least comply with category 3 as per EN ISO 13849.

There must be cross-circuit recognition for the command mechanism.

The wiring of the command mechanism must be two-channel with cross-circuit recognition.

The safety switching devices must have the option of signalling the cross-circuit recognition and of triggering recognition.

The switching capacity of the safety switching devices must at least correspond to the maximum permitted limited output current of the 24 V DC power supply. The manufacturer's information for the safety switching devices regarding the permissible contact loads and possibly required fuses for the safety contacts must be observed. If there is no manufacturer's information for this, the contacts must be fused at 0.6 times the nominal value of the maximum contact load cited by the manufacturer.

Command mechanisms with positively driven contacts and a locking function (as per EN 60947-5-1) must be used to trigger a safety-related cut-out of the drive under stop category 0 or 1 as per EN 60204-1 and fault-safe protection against restart as per EN ISO 13849 category 3.

The safety switching devices must be designed and connected in such a way that the resetting of the command device alone does not lead to the unit restarting. This means that a restart may only occur after the safety switching device has also been reset. The Indel servo drives themselves do not offer sufficient protection against unintentional restarting; this must be prevented using the safety switching device.

#### **Series connection of sensors under category 3**

- Emergency stop: can always be connected in series: simultaneous failure of the command devices can be excluded.
- Safety door monitoring: position switches can be connected in series if safety doors are opened simultaneously and regularly (otherwise errors cannot be covered).

#### **Series connection of sensors under category 4**

- Emergency stop: can always be connected in series: simultaneous failure of the command devices can be excluded.
- Safety door monitoring: position switches can never be connected in series because dangerous errors must be covered (regardless of the operating personnel).

## 11.2 Procedure for risk analysis and assessment

Every manufacturer of a machine must carry out a risk analysis in accordance with the Machinery Directive (2006/42/EC). This analysis is part of the declaration of conformity.

The risks and causes of the risks arising for persons and the environment from the operation of the machine/system are identified by the risk analysis. When identifying the risks and their causes, the entire life cycle – from development to transport, commissioning, operation and maintenance to disposal – is considered.

Risk reduction measures are developed to reduce the identified safety loopholes and/or risks. Finally, the residual risk is assessed.

## 11.3 Delimitation of the machine

The risk assessment begins by determining the boundaries of the machine, taking into account all phases in the life span of the machine.

Foreseeable misuse or misconduct must also be considered.  
(EN ISO 14121-1, chapter 5; EN ISO 12100-1, chapter 5.2)

### Usage limits

- Machine modes of operation
- Technical specifications with details on maximum utilisation, load, capacity
- Area of use of the machine (industrial, commercial, domestic)
- Training of the operator

### Spatial limits

- Interfaces with neighbouring systems and operators
- Area of movement
- Spatial requirements of persons handling the machine

### Time limits

- Life span of the machine
- Life span of the safety mechanisms
- Life span of parts subject to wear
- Maintenance intervals

### Further limits

- Environment-related limits such as operation in interior spaces, installation altitude, climatic conditions, maximum temperatures
- "Housekeeping": required degree of cleanliness (cleanrooms)



## 11.4 Identifying hazards

Hazards and their causes are identified with reasonable discretion in view of using the machine for its intended purpose.

The analysis of the dangers posed by a machine covers the entire life cycle.  
(EN ISO 14121-1 chapter 6; EN ISO 14121-1 A.3; EN ISO 12100-1 chapter 4, 5.3)

Phase of the life span of the machine	Hazard potential
Development, construction	<ul style="list-style-type: none"> <li>• Choice of materials</li> <li>• Dimensioning of components, machine parts</li> <li>• Specification of functions</li> <li>• Influence of ambient conditions</li> <li>• Life span</li> <li>• Compliance with applicable standards</li> <li>• State of the art</li> <li>• Documentation</li> </ul>
Transport	<ul style="list-style-type: none"> <li>• Compliance with permissible maximum weights of transport and lifting equipment (when loading and unloading)</li> <li>• Packing materials, transport securing devices</li> <li>• Transport routes: air, water, land</li> <li>• Climatic conditions during transport, storage at the destination</li> </ul>
Assembly and installation, commissioning	<ul style="list-style-type: none"> <li>• Preparation for installation (e.g. foundations, vibration damper)</li> <li>• Compliance with applicable provisions, standards at the assembly site</li> <li>• Connection to the disposal system (e.g. exhaust air system, waste water system)</li> <li>• Connection to the energy supply (e.g. power supply, compressed air)</li> <li>• Quality of energy supply, power cuts</li> <li>• ConFig.uration, programming of the control and devices</li> <li>• Feeding, filling, introduction of auxiliary fluids (e.g. lubricant, grease, adhesive)</li> <li>• Application of protective elements: protective grate, light curtain, floor mats</li> <li>• Fixing, anchoring</li> <li>• Commissioning checklists</li> <li>• Operation of the machine without load</li> <li>• Operation of the machine with a load and under full load</li> </ul>
Setup, teach-in, modification	<ul style="list-style-type: none"> <li>• Setting and setup of safety mechanisms and other components</li> <li>• Setting and setup or inspection of the functional parameters of the machine (e.g. speed, pressure, force, travelling limits)</li> <li>• Functional inspections, tests</li> <li>• Integration or replacement of tools, tool setting</li> <li>• Inspection of programming</li> <li>• Inspection of the end product</li> </ul>
Operation	<ul style="list-style-type: none"> <li>• Control/inspection</li> <li>• Driving of the machine</li> <li>• Feeding, filling, introduction of raw materials;</li> <li>• manual loading/unloading</li> <li>• Minor setting and setup procedures in the functional parameters of the machine (e.g. speed, pressure, force, travelling limits)</li> <li>• Minor interventions during operation (e.g. removal of waste products, removal of blocks, local cleaning)</li> <li>• Operation of the manual control mechanisms</li> <li>• Restart of the machine following a stop/interruption</li> </ul>

	<ul style="list-style-type: none"> <li>● Monitoring</li> <li>● Inspection of the end product</li> <li>● Measures for circumventing safety functions</li> </ul>
<p>Cleaning, installation, maintenance</p>	<ul style="list-style-type: none"> <li>● Settings</li> <li>● Cleaning, disinfection</li> <li>● Replacement of parts, components, mechanisms on the machine</li> <li>● Replacement of tools</li> <li>● Replacement of parts subject to wear</li> <li>● Energy isolation and dissipation</li> <li>● Handling of residual energy: mechanical, electrical</li> <li>● Lubrication</li> <li>● Renewed setup</li> <li>● Refilling of operating fluids</li> <li>● Inspection of parts, components, mechanisms on the machine</li> <li>● Restart following service, maintenance</li> </ul>
<p>Troubleshooting, remedying of errors</p>	<ul style="list-style-type: none"> <li>● Disassembly/assembly of parts, components, mechanisms on the machine</li> <li>● Energy isolation and dissipation</li> <li>● Restart after blocking</li> <li>● Restart after failure of control mechanisms and safety mechanisms</li> <li>● Replacement of safety-related parts</li> <li>● Availability of spare parts</li> <li>● Replacement of parts, components, mechanisms on the machine</li> <li>● Rescue of trapped persons</li> <li>● Renewed setup</li> <li>● Inspection of parts, components, mechanisms on the machine</li> </ul>
<p>Decommissioning, disassembly, disposal</p>	<ul style="list-style-type: none"> <li>● Isolation of the energy supply and energy dissipation</li> <li>● Disassembly</li> <li>● Lifting</li> <li>● Loading</li> <li>● Packing</li> <li>● Transportation</li> <li>● Unloading</li> <li>● Disposal</li> </ul>

### 11.4.1 Examples of hazards

#### ***Residual energy in intermediate circuit***

Danger posed by residual energy in the capacitors of the intermediate circuit of the servo controllers. When the 3-phase supply is isolated, the energy remains in the intermediate circuit.

This energy can be enough, when switched off (isolation of the energy through contactor with emergency stop), to accelerate a mass, which can cause personal injury or property damage.

#### ***Replacement of a drive with safety functions***

Danger when replacing devices with safety functions. A drive with safety functions may be replaced with, for example, a safety stop due to a defect when operating the machine. There is a risk that a replacement drive without a safety function will be installed.

#### ***Suspended loads, masses***

Danger posed by suspended masses. If the safety stop (STO) engages an axis with a suspended mass, the control of the motor is interrupted. This means that the motor can no longer bear a current and the mass will fall.

#### ***Engaging the pulse inhibitor in the case of running axes***

If the safety pulse inhibitor is engaged in the case of rotating axes, the motor can no longer be positioned and therefore can no longer be braked in a controlled manner. Axes spinning out can lead to damage to persons or property.

#### ***Manipulation of safety mechanisms***

Danger posed by manipulation of safety mechanisms due to time saving, ergonomics, productivity, etc.

### 11.5 Risk estimation

The severity, avoidability, frequency and duration of impact are estimated for every hazardous situation.

The aim of the risk estimation is to determine the required performance level for each hazardous situation.

(EN ISO 14121-1 chapter 7; EN ISO 62061 appendix A; EN ISO 13849-1 image A.1)

The required performance level (PLr) determined in this way is the basis for the determination of the safety architecture and selection of devices to guarantee the required safety.

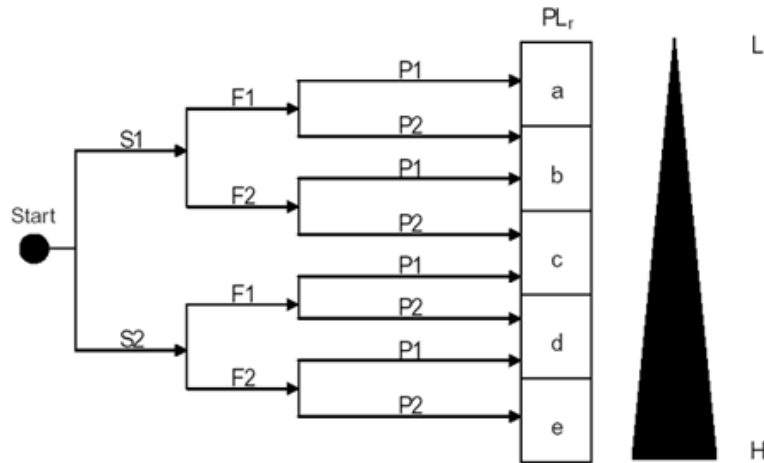

Fig. 18: Risk graph

#### Legend

Starting point for assessing the contribution to risk reduction

- L low contribution to risk reduction
- H high contribution to risk reduction
- PLr required performance level

#### Risk parameters

- S Severity of the injury
- S1 slight (normally reversible injury)
- S2 serious (normally irreversible injury, including death)
  
- F Frequency and/or duration of exposure to the danger
- F1 rare to less frequent and/or the time of exposure to the danger is short
- F2 frequent to permanent and/or the time of exposure to the danger is long
  
- P Possibility of avoiding the danger or limiting the damage
- P1 possible under certain conditions
- P2 barely possible

**Performance level, SIL level**

The performance level shows the likelihood of a dangerous failure / hour.

In order to be able to reduce a hazard with this risk estimation:

- S2** serious (normally irreversible injury, including death)
- F1** rare to less frequent and/or the time of exposure to the danger is short
- P1** possible under certain conditions
- > required **PLr = c**

to be reduced to an acceptable risk, a safety system with a likelihood of failure of less than  $3 \cdot 10^{-6}$  must be used.

Kategorien nach EN-954-1	SIL Level nach IEC 61508	Wahrscheinlichkeit eines Ausfalles 1/h 1)	Performance Level
B	keine Anf.	$\geq 10E-5 \dots < 10E-4$	a
1	SIL1	$\geq 3 \cdot 10E-6 \dots < 10E-5$	b
2	SIL1	$\geq 10E-6 \dots < 3 \cdot 10E-6$	c
3	SIL2	$\geq 10E-7 \dots < 10E-6$	d
4	SIL3	$\geq 10E-8 \dots < 10E-7$	e
	SIL4	$\geq 10E-9 \dots < 10E-8$	

Fig. 19: Performance level - SIL level

**SIL level, likelihood of failure and operating mode**

In EN 61508-1, a distinction is made between applications with low requirements and applications with high or continual requirements.

Sicherheits-Integritätslevel	Betriebsart mit niedrigen Anforderungen (PFD) Ausfallwahrscheinlichkeit bei Anforderung
SIL1	$\geq 10E-2 \dots < 10E-1$
SIL2	$\geq 10E-3 \dots < 10E-2$
SIL3	$\geq 10E-4 \dots < 10E-3$

Sicherheits-Integritätslevel	Betriebsart mit hoher, kontinuierlicher Anforderungen (PFH) Ausfallwahrscheinlichkeit / Stunde
SIL1	$\geq 10E-6 \dots < 10E-5$
SIL2	$\geq 10E-7 \dots < 10E-6$
SIL3	$\geq 10E-8 \dots < 10E-7$

Fig. 20: SIL level with low and high requirements

Operating mode with low requirements (PFD): The safety-related system is not actuated more than once per year. The SIL level describes the likelihood of failure upon use of the function

Operating mode with a high requirement rate or continual requirement (PFH): The safety-related system is actuated more than once per year. The continual requirement relates to safety-related systems that carry out continual control or monitoring in order to maintain functional safety.

## 11.6 Risk assessment

Following the risk estimation, a risk assessment must be carried out in order to decide whether risk reduction is necessary.

If risk reduction is necessary, suitable measures must be selected and applied.

It must also be considered that a measure for risk reduction may, in turn, hold potential for new risks.

Should additional dangers occur, these must be added to the list of identified hazards, and suitable protective measures must be taken in order to combat these.

(EN ISO 14121-1 chapter 8)

### 11.6.1 Examples of risk assessment

#### ***Suspended loads, masses***

The danger posed by the suspended load is reduced with mechanical blocking.

→ The risk then arises that the mechanical block could be defective.

#### ***Residual energy in intermediate circuit***

The danger posed by residual energy in the capacitors of the intermediate circuit of the servo controllers is reduced with a braking resistor. This resistor should destroy the energy in the intermediate circuit when the energy supply to the drive is disconnected.

→ However, there remains a risk that the braking resistor could be defective or not connected.

### 11.7 Risk reduction

The identified risks and hazards, and their unacceptable effects, are reduced following the 3-step procedure:

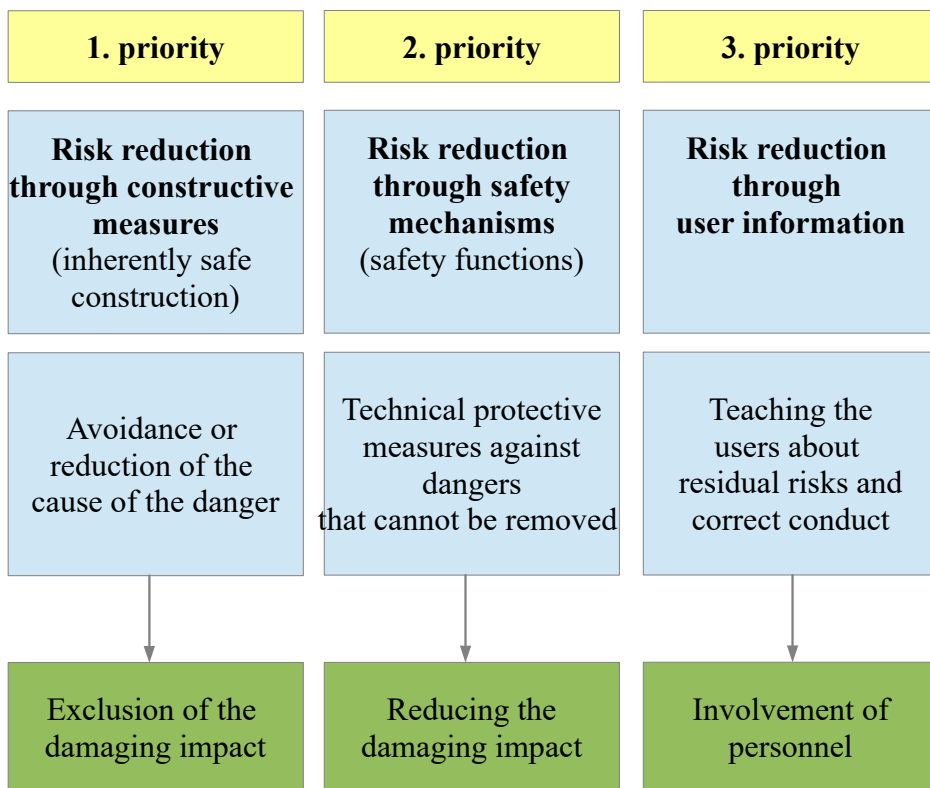

Often the original hazards cannot be avoided or reduced as they serve the intended purpose of the machine.

Risks arising from a rotating chuck for a lathe cannot be removed by the non-rotation of the chuck.

Technical protective measures, such as a locked hood or cover, will reduce the danger.

A residual risk, such as that of splinters flying off the tool, can only be eliminated by means of correct conduct on the part of the operating personnel.

(EN ISO 12100-1, chapter 5.4, 5.5, EN ISO 14121-1 chapter 8.2, EN ISO 13849-1, chapter 4.2)

## 11.7.1 Examples of protective measures for risk reduction

### ***Residual energy in intermediate circuit***

Danger posed by residual energy in the capacitors of the intermediate circuit of the servo controllers. When the 3-phase supply is isolated, the energy remains in the intermediate circuit.

- Monitoring the intermediate circuit voltage
- Destruction of the energy using a braking resistor
- Mechanical brakes
- Safety pulse inhibitor (STO)

### ***Replacement of a drive with safety functions***

Danger when replacing devices with safety functions. A drive with safety functions may be replaced with, for example, a safety stop due to a defect when operating the machine. There is a risk that a replacement drive without a safety function will be installed.

- Training of the service personnel
- Periodic testing of the safety function during operation using software
- Identification of the safety function before switch-on using software

### ***Suspended loads, masses***

Danger posed by suspended masses. If the safety stop (STO) engages an axis with a suspended mass, the control of the motor is interrupted. This means that the motor can no longer bear a current and the mass will fall.

- Mechanical brakes, locking
- Only engage STO in a safe parked position

### ***Engaging setup mode with a key switch***

- Training of the service personnel
- Safely reduced speed during setup mode
- Two-hand actuation during setup mode
- Enabling button for setup mode
- Light curtain



## 11.8 Implementing the safety functions

The safety system is selected based on the required performance level (PLr) that was determined in the risk estimation for each individual risk.

This means that a safety system with a performance level of PL=e can eliminate a risk corresponding to PLr=e.

### 11.8.1 Performance level of the safety system

The PL of the safety system is defined by means of estimation of the following aspects:

- the MTTFd value of individual components (EN ISO 13849-1, appendices C and D);
- the DC (EN ISO 13849-1, appendix E);
- the CCF (EN ISO 13849-1, appendix F);
- the structure (EN ISO 13849-1, section 6);
- the behaviour of the safety function under error conditions (EN ISO 13849-1, section 6);
- safety-related software (EN ISO 13849-1, ch. 4.6 and appendix J);
- systematic failures (EN ISO 13849-1, appendix G);
- the ability of a safety function to carry out its task under foreseeable ambient conditions.

### 11.8.2 Mean time to failure (dangerous) (MTTFd)

The value for the MTTFd of each channel is given in three stages and must be considered individually for each channel (e.g. only channel or each channel of a redundant system).

In terms of the MTTFd, a maximum value of 100 years can be applied.

MTTF <sub>d</sub>	
Bezeichnung für jeden Kanal	Bereich für jeden Kanal
niedrig	3 Jahre ≤ MTTF <sub>d</sub> < 10 Jahre
mittel	10 Jahre ≤ MTTF <sub>d</sub> < 30 Jahre
hoch	30 Jahre ≤ MTTF <sub>d</sub> ≤ 100 Jahre

ANMERKUNG 1 Die Wahl der MTTF<sub>d</sub>-Bereiche eines Kanals basiert nach dem in der Praxis vorgefundenen Stand der Technik auf einer logarithmischen Skala, die sich der logarithmischen Skala des PL anpasst. Es wird nicht angenommen, dass ein MTTF<sub>d</sub>-Wert eines Kanals für ein reales SRP/CS kleiner als drei Jahre gefunden werden kann, denn das würde bedeuten, dass nach einem Jahr etwa 30 % aller Systeme auf dem Markt defekt sind und ersetzt werden müssten. Ein MTTF<sub>d</sub>-Wert eines Kanals größer als 100 Jahre wird nicht akzeptiert, denn ein SRP/CS für hohe Risiken sollte nicht von der Zuverlässigkeit von Bauteilen alleine abhängig sein. Um ein SRP/CS gegen systematische und zufällige Fehler zu ertüchtigen, sind zusätzliche Mittel wie Redundanzen und Tests erforderlich. Für die praktische Anwendbarkeit wurde die Zahl der Bereiche auf drei beschränkt. Die Beschränkung des MTTF<sub>d</sub>-Wertes jedes Kanals auf ein Maximum von 100 Jahren bezieht sich auf den einzelnen Kanal des SRP/CS, der die Sicherheitsfunktion ausführt. Höhere MTTF<sub>d</sub>-Werte können für einzelne Bauteile verwendet werden (siehe Tabelle D.1).

ANMERKUNG 2 Für die gezeigten Grenzwerte der Tabelle 5 wird eine Genauigkeit von 5 % angenommen.

Fig. 21: Mean time to failure (dangerous) MTTFd

### 11.8.3 Diagnostic coverage DC

The value for the DC is given in four stages.

Bezeichnung	DC	
	Bereich	
kein	DC < 60 %	
niedrig	60 % ≤ DC < 90 %	
mittel	90 % ≤ DC < 99 %	
hoch	99 % ≤ DC	

ANMERKUNG 1 Für ein SRP/CS, das aus mehreren Teilen besteht, wird in dieser Norm in Bild 5, Abschnitt 6 und E.2 ein Durchschnittswert  $DC_{avg}$  für den DC verwendet.

ANMERKUNG 2 Die Wahl der DC-Bereiche basiert auf den Schlüsselwerten 60 %, 90 % und 99 %, die ebenfalls in anderen Normen, die sich mit Diagnosedeckungsgrad und Tests beschäftigen, eingeführt sind (z. B. IEC 61508). Untersuchungen zeigen, dass (1-DC) eher als DC selbst eine typische Maßeinheit für die Effektivität eines Tests ist. (1-DC) für die Schlüsselwerte 60 %, 90 % und 99 % bildet eine Art logarithmische Skala, die sich der logarithmischen Skala des PL anpasst. Ein DC-Wert kleiner als 60 % hat nur geringen Einfluss auf die Zuverlässigkeit eines getesteten Systems und wird deshalb mit „kein“ bezeichnet. Ein DC-Wert für komplexe Systeme größer als 99 % ist nur sehr schwer zu erreichen. Für die praktische Anwendbarkeit wurde die Zahl der Bereiche auf vier beschränkt. Für die gezeigten Grenzwerte dieser Tabelle wird eine Genauigkeit von 5 % angenommen.

Fig. 22: Diagnostic coverage DC

For calculation of the DC see EN ISO 13849-1 appendix E.

### 11.8.4 Common cause failures CCF

The likelihood of a dangerous failure of the safety function is not only dependent on the following factors:

- Hardware and software structure
- Scope of the error detection mechanisms (diagnostic coverage DC)
- Reliability of components (mean time to failure (dangerous) MTTFd)
- Design process
- Stress during operation
- Ambient conditions and operating conditions,

but also on common cause failures (CCF). Important measures to combat common cause failures are:

- Physical separation of the signal paths: separation of the wiring/piping, sufficient air and creep distances on pressurised circuits
- Different technologies/design or physical principles, e.g.:
- the first channel in programmable electronics and the second channel with fixed wiring, measurement of distance and pressure, digital and analogue, components from different manufacturers.
- Protection against overvoltage, overpressure, overcurrent etc.
- Use of tried and tested components
- Training of designers/assemblers so that they recognise the reasons for and effects of common cause failures
- Protection against soiling and electromagnetic influences (EMC)
- Requirements in terms of insensitivity to temperature, shock, vibration, moisture

## 11.9 The categories and their relationship with the MTTFd of each channel, DC and CCF

The architecture of a safety system is a key characteristic with great influence on the PL.

Even if the variety of possible structures is great, the fundamental concepts are often similar.

This means that the majority of structures that exist in the field of machines can be put into one of the following categories.

It is important that the PL set out in Fig. 28, which is dependent on the category, the MTTFd of each channel and the DC, is based on foreseen architectures.

### 11.9.1 Category B

In systems under category B there is no diagnostic coverage (DC = none), and the MTTFd of each channel can be low to medium.

In such structures (normally one-channel systems), considering CCF is not relevant.

The maximum PL that can be achieved with category B is  $PL = b$ .

Category B systems should not be used.

**Occurrence of an error can lead to loss of the safety function.**

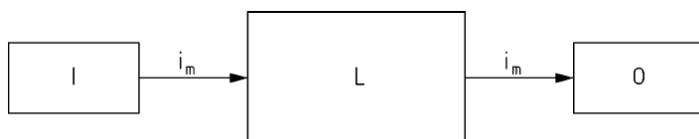

Fig. 23: Architecture, category B

#### Legend

- $i_m$  Means of connection
- I Input unit, e.g. sensor
- L Logic
- O Output unit, e.g. main contactor

## 11.9.2 Category 1

Safety systems under category 1 must be designed and constructed using tried and tested components and safety principles (see EN ISO 13849-2).

The MTTFd of each channel must be high.

The maximum PL that can be achieved with category 1 is  $PL = c$ .

There is no diagnostic coverage ( $DC = \text{none}$ ) in systems under category 1. In such structures (one-channel systems), considering CCF is not relevant.

**Occurrence of an error can lead to loss of the safety function.**

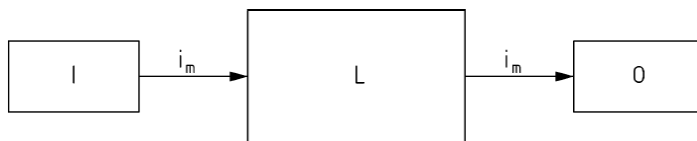

Fig. 24: Architecture, category 1

### Legend

- $i_m$  Means of connection
- I Input unit, e.g. sensor
- L Logic
- O Output unit, e.g. main contactor

### 11.9.3 Category 2

Safety systems under category 2 must be designed in such a way that their functions are tested at regular intervals by the machine control. The test of the safety function(s) must be carried out:

- when starting the machine and
- before introducing a hazardous situation, e.g. when starting a new cycle, when starting other movements, and/or periodically during operation

The maximum PL that can be achieved with category 2 is PL = d.

**The system behaviour under category 2 allows for the occurrence of an error between the tests to lead to loss of the safety function or for the loss of the safety function to be recognised by the test.**

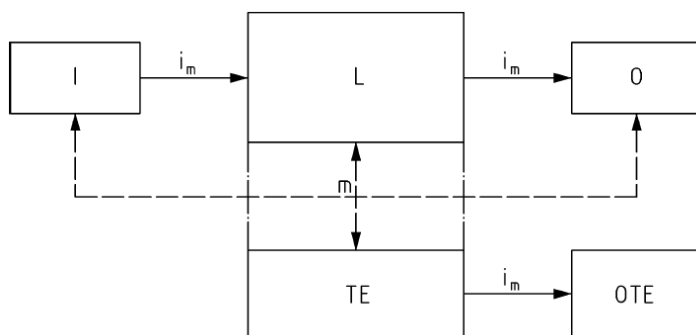

Fig. 25: Architecture, category 2

**Legend**

- $i_m$  Means of connection
- I Input unit, e.g. sensor
- L Logic
- m Monitoring
- O Output unit, e.g. main contactor
- TE Testing mechanism
- OTE Output for the testing mechanism

### 11.9.4 Category 3

Safety systems under category 3 are two-channel. They must be designed in such a way that a single error in one of these parts does not lead to loss of the safety function.

Wherever possible and suitable, an individual error must be identified during or before the next use of the safety function.

Measures against CCF must be used.

**A single error does not lead to loss of the safety function.  
The accumulation of unidentified errors can lead to loss of the safety function.**

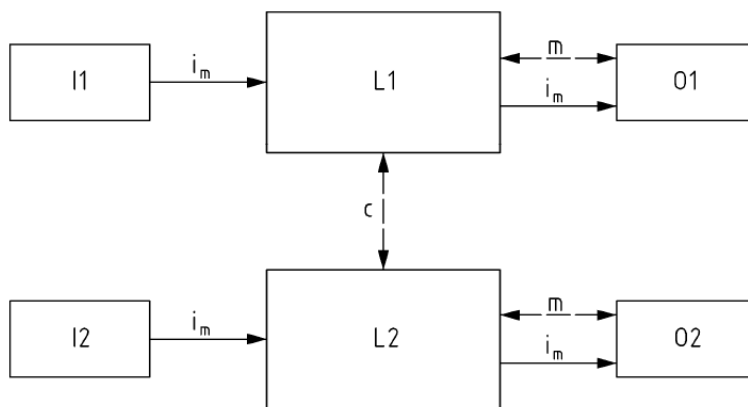

Fig. 26: Architecture, category 3

#### Legend

- i<sub>m</sub> Means of connection
- c Cross-comparison
- I1, I2 Input units, e.g. sensor
- L1, L2 Logic
- m Monitoring
- O1, O2 Output units, e.g. main contactor

### 11.9.5 Category 4

Safety systems under category 4 are designed with two-channels. They must be designed in such a way that a single error in one of these parts does not lead to loss of the safety function.

The diagnostic coverage (DC) of the entire safety system must be high.

The  $MTTF_d$  of each redundant channel must be high.

Measures against CCF must be used (see appendix F).

The difference between category 3 and category 4 is the higher DC in category 4 and the required  $MTTF_d$ , which must be “high”.

**The safety function is always executed if an individual error occurs.  
 Errors are identified in good time in order to prevent loss of the safety function.  
 Accumulation of unidentified errors will be considered.**

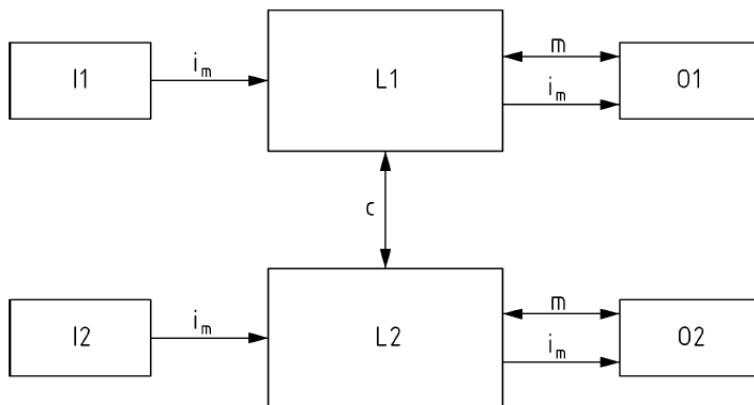

Fig. 27: Architecture, category 4

**Legend**

- $i_m$  Means of connection
- $c$  Cross-comparison
- I1, I2 Input units, e.g. sensor
- L1, L2 Logic
- $m$  Monitoring
- O1, O2 Output units, e.g. main contactor

### 11.9.6 Relationship between MTTFd, DC, PL and categories

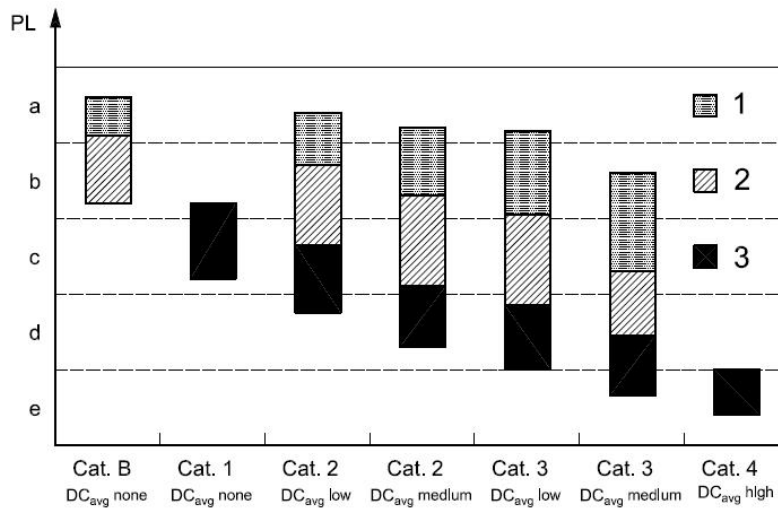

Fig. 28: Relationship between the categories DC, MTTFd of each channel and PL

**Legend**

- PL Performance level
- 1 MTTFd of each channel = low
- 2 MTTFd of each channel = medium
- 3 MTTFd of each channel = high

**Example of performance level**

Kategorie	B	1	2	2	3	3	4
DC <sub>avg</sub>	kein	kein	niedrig	mittel	niedrig	mittel	hoch
MTTF <sub>d</sub> jedes Kanals							
niedrig	a	nicht abgedeckt	a	b	b	c	nicht abgedeckt
mittel	b	nicht abgedeckt	b	c	c	d	nicht abgedeckt
hoch	Nicht abgedeckt	c	c	d	d	d	e

Fig. 29: Tabular relationship between the categories DCavg, MTTFd of each channel + PL

In order to be able to reduce a hazard with this risk estimation:

- S2** serious (normally irreversible injury, including death)
- F1** rare to less frequent and/or the time of exposure to the danger is short
- P1** possible under certain conditions
- > required **PLr = c**

to an acceptable risk, a safety system with the characteristics marked in red can be used.

- Category 1, DC=small, MTTFd=high
- Category 2, DC=low, MTTFd=high
- Category 2, DC=medium, MTTFd=medium
- Category 3, DC=low, MTTFd=medium
- Category 3, DC=medium, MTTFd=low



### 11.9.7 Combining safety devices

A safety function can be implemented by combining several safety devices:

- Input system
- Signal processing
- Output system.

This combination may comprise partial systems of different categories. An overall PL can be determined for the entire system according to Fig.. 31 . (EN ISO 13849-1, chapter 6.3)

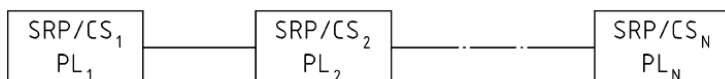

Fig. 30: Combining safety systems to achieve the overall PL

**Legend**

SRP/CS Safety-related part of a control  
 PL Performance level

PL <sub>niedrig</sub>	$\lambda_{niedrig}$	⇒	PL
a	> 3	⇒	kein, nicht erlaubt
	≤ 3	⇒	a
b	> 2	⇒	a
	≤ 2	⇒	b
c	> 2	⇒	b
	≤ 2	⇒	c
d	> 3	⇒	c
	≤ 3	⇒	d
e	> 3	⇒	d
	≤ 3	⇒	e

ANMERKUNG Die für das Nachschlagen berechneten Werte basieren auf Zuverlässigkeitswerten für die Mitte jedes PL.

Fig. 31: Calculating the PL for series connection of safety devices

## 11.10 Methods for troubleshooting

Example of troubleshooting with FMEA (*Failure Mode and Effects Analysis*):

Risikobewertung	Maschine: Teilsystem:	Schwere der Verletzung (S) S1 leichte (üblicherweise reversible Verletzung) S2 ernste (üblicherweise irreversibile Verletzung einschliesslich Tod) Häufigkeit und Dauer der Gefährdungsexposition (F) F1 selten bis weniger häufig und/oder die Zeit der Gefährdungsexposition ist kurz F2 häufig bis dauernd und/oder die Zeit der Gefährdungsexposition ist läng	Möglichkeit der Vermeidung der Gefährdung oder Begrenzung des Schadens (P) P1 möglich unter bestimmten Bedingungen P2 kaum möglich	Geforderter Performance Level (PLr) a, b, c, d, e											
					Nr.	Beschreibung der Betriebsart	Gefährdungssituation	Person im Gefahrenbereich	Nr. Ursache	Ereignis	geforderter PL	Schutzziel	Massnahmen	PLr Restrisiko	Hinweise
1. Maschine	Verletzung durch 1.1 bewegende Teile	Verletzungen des Bedieners	1.1.1	Restenergie im Zwischenkreis - 1.1.1 Zwischenkreis	Sach- und Personenschäden durch bewegende Maschinenteile, in der Zeit zwischen Trennung der Energie und vollständiger Entladung der Zwischenkreis-Energie	\$2	F2	P1	d	Keine Verletzungen möglich	- Extern Enable abschalten - mit Not-Stop Bremsrampe Achse stoppen - Zwischenkreis mit Bremswiderstand entladen - STO ändern nachdem Achsen stillgesetzt sind - Zwischenkreisspannung überwachen	S1	F2	P1	b
2. Intervall	Wiederschalten nach Service	Verletzungen des Bedieners	2.1	Ersatzgerät ohne Sicherheitsfunktion	Verlust der Sicherheitsfunktion	\$2	F1	P1	c	Sicherheitsgeräte beinhalten korrekte Sicherheitsfunktionen	- Software überprüft das vorhanden sein der Korrekten Sicherheitsfunktionen - Schulung des Personals - Checklisten	S1	F1	P1	a
3. Betrieb	Unkontrollierte Achsen	Verletzungen des Bedieners	3.1	Sicherheitsfunktion STO im Betrieb	Achsen trudeln aus, Achsen sind unkontrollierbar aufgrund der sicheren Impulsparze	\$2	F1	P1	c	Sicherer Zustand bei Anforderung der Sicherheitsfunktion	- verriegelte Schutztüren, öffnen erst nachdem die Achsen stillgelegt sind - Achsen mit Not-Stop Bremsrampe stoppen, STO zeitverzögert ändern	S1	F1	P1	a
4. Einrichtbetrieb	Vertikale Achsen mit herabfallenden Massen	Verletzungen des Bedieners	4.1	STO wird angefordert während Achse im sicheren Betriebszustand	Drive kann Haltemoment nicht mehr aufbringen, Achse unkontrollierbar aufgrund der sicheren Impulsparze	\$2	F1	P1	c	Sicherer Zustand bei Anforderung der Sicherheitsfunktion	- sichere Bremsel - sichere Parkposition	S2	F1	P1	a
5. Einrichtbetrieb	Achsen bewegen sich zu schnell	Verletzungen des Bedieners	5.1	4.1.2 Bremsen defekt	Massen fällt herunter	\$2	F1	P1	c	Sicherer Zustand bei Anforderung der Sicherheitsfunktion	- mechanisch verriegelte Bremse - Verriegelung mit Schliesser-Kontakt überwachen - Verriegelte Schutztüre, öffnet nur bei verriegelter Bremse	S1	F1	P1	a
6. Betrieb	Überbrückte Sicherheitsfunktionen	Verletzungen des Bedieners	6.1	Fehlerhafte zu hohe Geschwindigkeitsvorgabe	Sach- und Personenschäden durch bewegende Maschinenteile	\$2	F2	P1	c	Keine Verletzungen möglich	- Schulung Service-Personal - Sicher red. Geschw. während Einrichtbetrieb - Zuhand-Betätigung während Einrichtbetrieb - Lichtschranke	S1	F1	P1	a
					Sach- und Personenschäden durch bewegende Maschinenteile	\$2	F1	P1	c	Keine Manipulation von Schutzanrichtungen	- Feinjustierung mit Einstellelementen ausserhalb von Abdeckungen - Einstellungen erfolgen elektronisch über Bedienung bei geschlossener Abdeckung	S1	F1	P1	a

Fig. 32: Troubleshooting with FMEA

## **11.11 Verification, validation of the safety function**

### **11.11.1 Verification**

For each individual safety function, the performance level (PL) of the corresponding safety element must correspond to the required performance level from the risk estimation.

(EN ISO 13849-1 chapter 4.7)

### **11.11.2 Validation**

The purpose of the validation procedure is to confirm the specification and conformity of the design of the safety-related parts of the control within the overall specifications for the safety requirements of the machine.

The validation must show that each safety-related part fulfils the requirements, particularly in terms of

- the defined safety characteristics of the safety functions for this part, as realised in the logical design, and
- the requirements of the defined category. The validation should be carried out by persons that are not involved in the design of the safety-related parts.

(EN ISO 13849-1 chapter 8; EN ISO 13849-2; EN 62061, chapter 8)

## **11.12 Technical documentation**

When designing a safety system, the designer must at least document the following documentation on the safety-related part:

- the safety function(s) provided by the SRP/CS;
- the characteristics of each safety function;
- the exact points at which the safety-related parts begin and end;
- the ambient conditions;
- the performance level (PL);
- the selected category or categories;
- the parameters relating to reliability (MTTFd, DC, CCF and duration of use);
- the measures against systematic errors;
- the technology or technologies used;
- all safety-related errors that have been taken into account;
- the justification for exclusion of errors (see ISO 13849-2);
- the justification for the design (e.g. errors considered, excluded errors);
- software documentation;
- measures against reasonably foreseeable misuse.

### 11.13 Connection examples

All connection examples are non-binding. The user is responsible for the binding layout of the safety functions (SF). The user must observe the state of the art in the corresponding European standards, such as EN ISO 13849-1/-2, EN 62061, EN 1088, etc.

#### 11.13.1 STO with locked safety door

Safety stop STO with locked safety door and emergency stop.  
 Stop category 1  
 Safety category 3

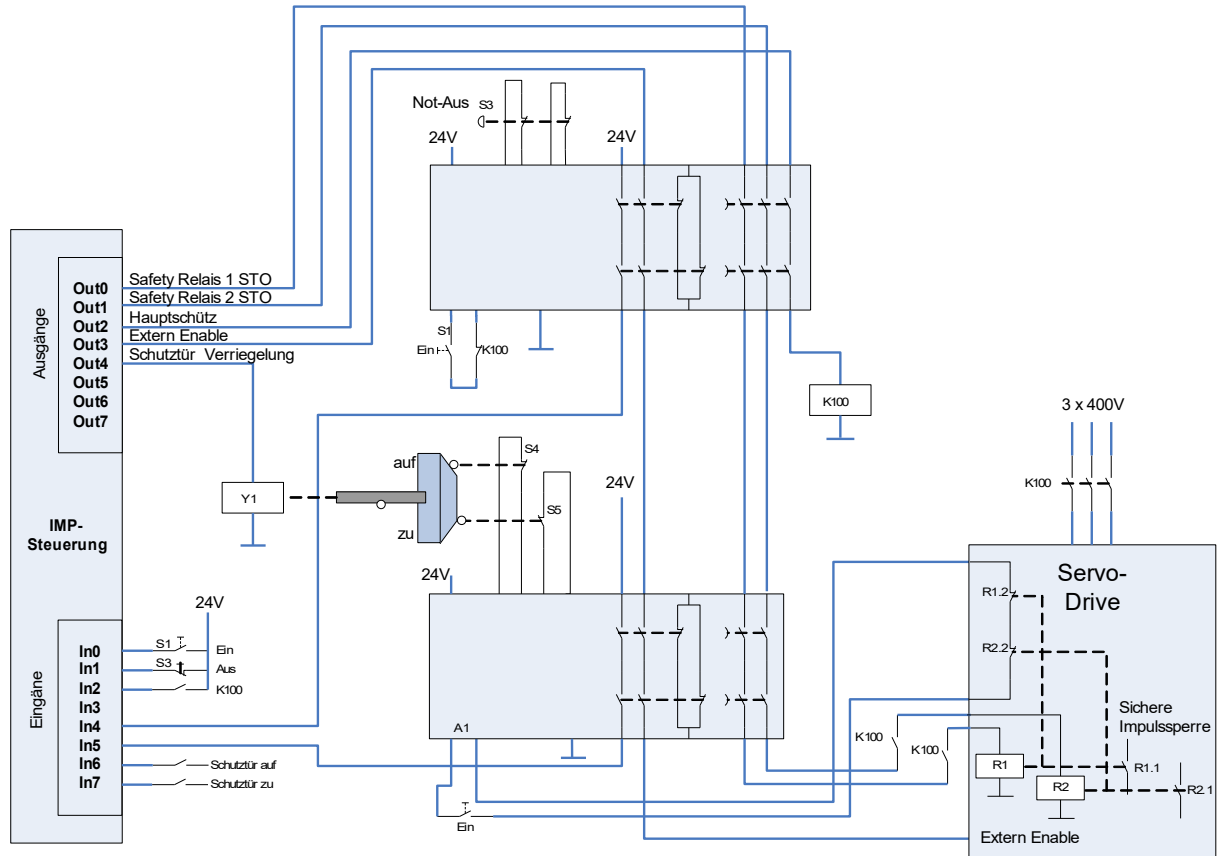

Fig.. 33: STO, locked safety door

### 11.13.2 STO with a safety switching device

Safety stop STO with locked safety door and emergency stop.  
 Stop category 1  
 Safety category 3  
 only one safety switching device

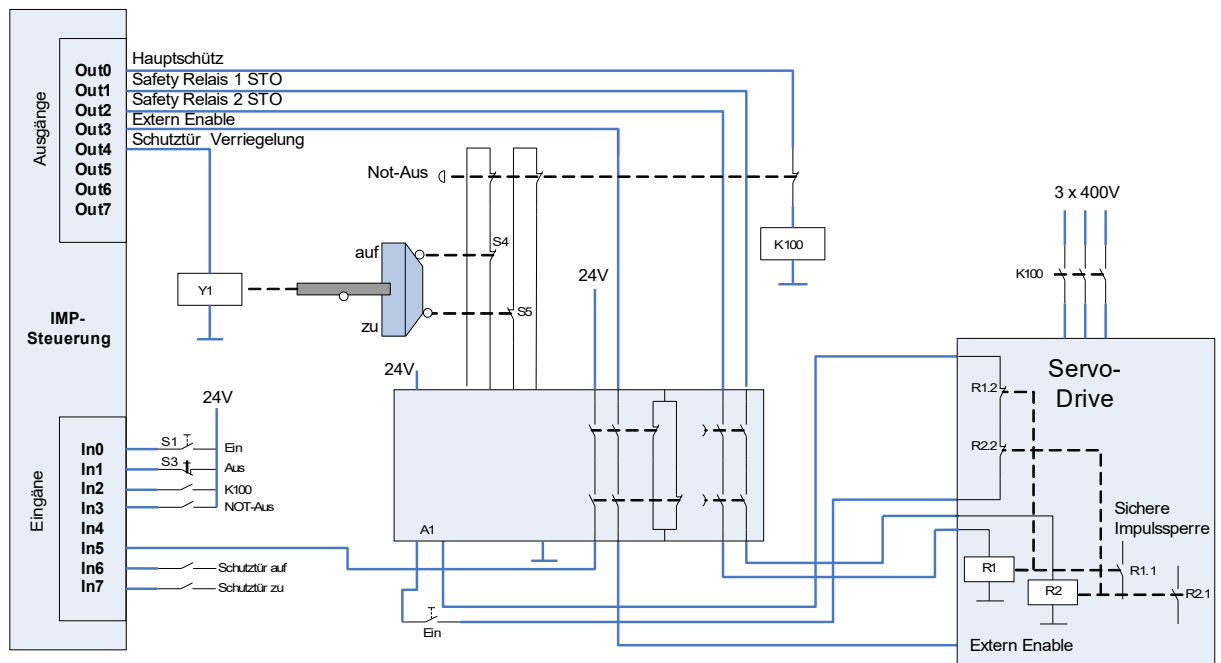

Fig. 34: STO with a safety switching device

### 11.13.3 STO with enabling switch

Safety stop STO with locked safety door and emergency stop.  
 Stop category 1  
 Safety category 3  
 only one safety switching device  
 Bypassing the safety door with a key switch and enabling switch

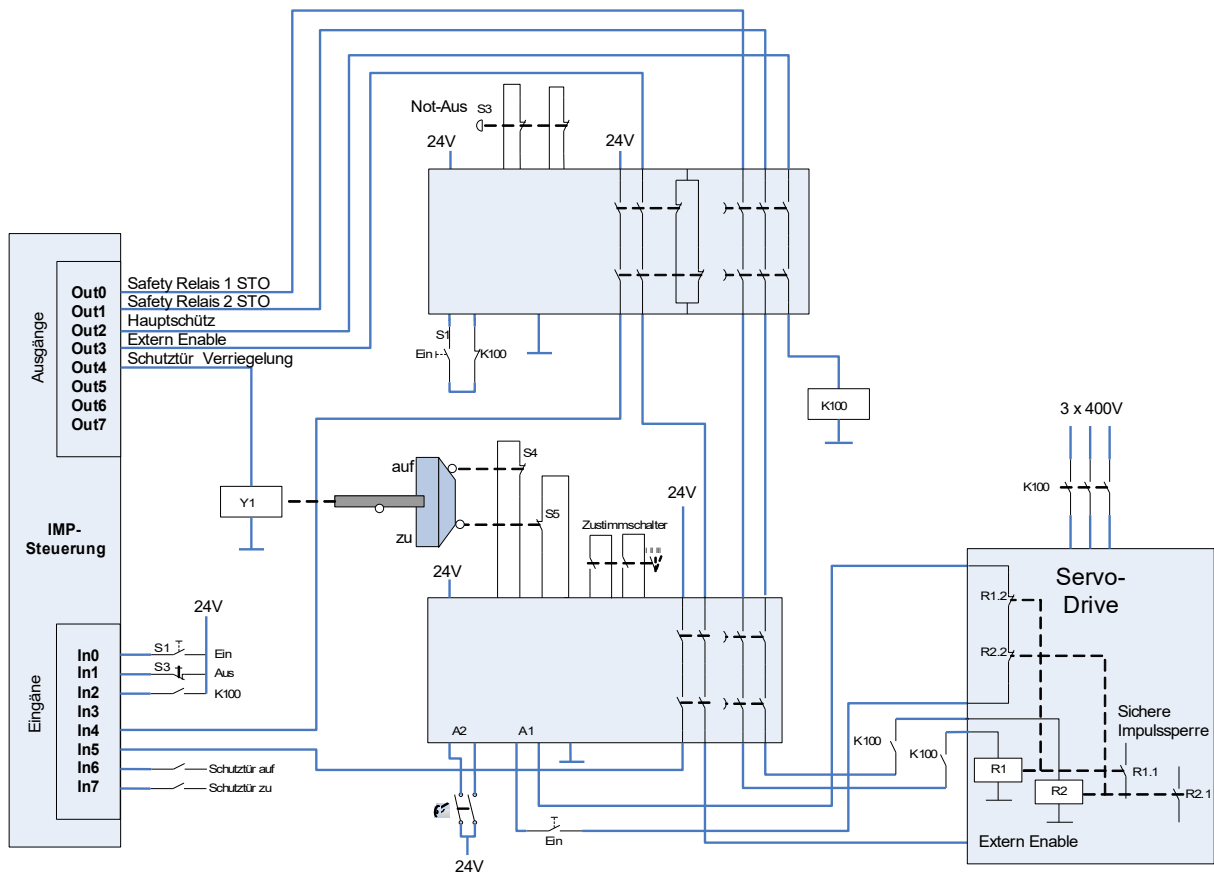

Fig. 35: STO with enabling button

## 12 List of Figures

Fig. 1: Rating plate.....	13
Fig. 2: SAC 2.5A, 4A/230V.....	21
Fig. 3: SAC 5A.....	21
Fig. 4: SAC 16/24A.....	21
Fig. 5: SAC3x3.....	22
Fig. 6: Fan connection, SAC3x3.....	25
Fig. 7: Functional principle of safety stop.....	31
Fig. 8: Safety stop.....	31
Fig. 9: Pin X100.....	31
Fig. 10: Pin assignment 1.....	34
Fig. 11: Pin assignment 2.....	34
Fig. 12: Connection example for 24V single-ended incremental encoder.....	42
Fig. 13: Connection example for 5V single-ended incremental encoder.....	42
Fig. 14: RJ pin.....	43
Fig. 15: No jumper, 10m jumper, 30m jumper.....	45
Fig. 16: Status LEDs of SAC drives.....	46
Fig. 17: Type certificate, SAC3 drives.....	53
Fig. 18: Risk graph.....	60
Fig. 19: Performance level - SIL level.....	61
Fig. 20: SIL level with low and high requirements.....	61
Fig. 21: Mean time to failure (dangerous) MTTFd.....	65
Fig. 22: Diagnostic coverage DC.....	66
Fig. 23: Architecture, category B.....	67
Fig. 24: Architecture, category 1.....	68
Fig. 25: Architecture, category 2.....	69
Fig. 26: Architecture, category 3.....	70
Fig. 27: Architecture, category 4.....	71
Fig. 28: Relationship between the categories DC, MTTFd of each channel and PL.....	72
Fig. 29: Tabular relationship between the categories DCavg, MTTFd of each channel + PL.....	72
Fig. 30: Combining safety systems to achieve the overall PL.....	73
Fig. 31: Calculating the PL for series connection of safety devices.....	73
Fig. 32: Troubleshooting with FMEA.....	74
Fig. 33: STO, locked safety door.....	76
Fig. 34: STO with a safety switching device.....	77
Fig. 35: STO with enabling button.....	78

**Disclaimer**

No guarantee is made for the correctness or completeness of the information provided. Subject to technical changes.

**File-History**

1.16	29.04.2011	Gin-SAC3x3, GIN-SAC3 with STO certificate, rating plate adapted, hot surface for SAC3x3, list of Fig.ures
3.17	16.05.2011	SUVA certificate
3.18	05.07.2011	New rating plate design
3.19	18.07.2011	Type certificate SAC3, SAC3x3
3.20	30.09.2011	Disclaimer added, FMEA completed with PL
3.21	04.09.2011	Fan connection, SAC3x3
3.22	16.11.2011	Switch-on current < 2A, connecting intermediate circuits of max. 5 drives in parallel
3.23	20.12.2011	Key words X5, SIO added to serial interface.
3.24	09.02.2012	Correction of inc to absolute feedback inputs: IncA to Clk, IncB to Data
3.25	21.02.2012	SAC3x3 9-pole D-sub interface deleted. Single-ended incremental encoder interface deleted. Connection example for 24V / 5V single-ended inc encoder
3.26	02.03.2012	Digital IOs of SAC3x3 added. SAC3x3 bi-metal temp. sensor removed.
3.27	09.05.2012	Dimensions of SAC3 2.5A 4A/230V (Fig..2) corrected
3.28	12.06.2012	Type GIN-SAC3 4A/230V referred to Fig.. 2
3.29	01.10.2012	Change of pin designation of SAC3 SinCos interface pin X14A pin 4 new V2.
3.30	12.10.2012	More precise description for assembly of the SAC3x3
3.31	12.10.2012	Express reference to exclusion of liability in the case of non-compliance with ambient and operating conditions
3.32	21.12.2012	Section 5.3.2 Correction of incremental encoder to SinCos inputs: IncA to Cos, IncB to Sin Note on RS422 with 120 Ohm completed. The encoder must be able to deal with this load Incremental encoder to absolute feedback system is now also supported in the GIN-SAC3
3.33	26.04.2013	Section 11.13.4, Safe slow speed with reduced supply, removed
3.34	04.11.2013	Chapter 3.1 add tip for additional cooling measures to keep the ambient temperature below 40°C. Increase the minimum distance between servo drives to 50mm
3.35	02.04.2015	Decrease the minimum distance between servo drives back to 10mm
3.36	02.04.2015	Corrected the reaction time $t_{OFF}$ of the STO from 3ms to 15ms. Chapter 3.1 Corrected the time $t_{SIS}$ in chapter 4.5 from 3ms to 15ms
3.37	19.04.2016	BMX: Conformity adjusted according to current guidelines, Chapter 10.3
3.38	05.08.2016	BMX: Adjustment of the safety requirements in chapter 1.2 and adjustment of the standards in chapter 8
3.39	22.02.2017	BMX: Prolongation of the type-examination certificates E 6929 in chapter 10.2. and E 6930
3.40	07.10.2020	BMX: Update EC Declaration of Conformity in chapter 10.3
3.41	10.09.2021	BMX: Update EC Declaration of Conformity in chapter 10.3
3.42	24.02.2022	BMX: Prolongation of the type-examination certificate E 6929 in chapter 10.2
3.43	30.09.2022	BMX: Update EC Declaration of Conformity in chapter 10.3
3.44	14.09.2023	MF: Update EC Declaration of Conformity in chapter 10.3 MF: SAC3x3 Product state END OF LIFE, Certificate E6930 delted
3.45	05.09.2024	MF: Update in Chapter 10.3 replaced copy of EC decleration with link MF: Fax deleted