



Wiring Guidelines

Rev. 1.6

Indel AG
Tüfiwis 26
CH-8332 Russikon, Switzerland

Contents

1	Purpose of these Guidelines	5
2	Input filters, line filters	6
2.1	Filtering of assemblies	6
2.2	Line entry filter	6
3	Ferrite	7
3.1	Filter types	7
3.2	Applications	7
4	Shielding	8
4.1	Bonding conductor	8
4.2	Ground conductor	10
4.3	Interface cables	10
5	Grounding (earthing)	10
5.1	Cabinet grounding	10
5.2	Kupal	10
6	Cabinet lighting	10
7	Protection against ESD	11
8	Capacitive limit switches	12
8.1	Installation of sensors	12
8.2	Wiring of sensors	12
8.3	Application	12
9	Cable installation	13
9.1	Cable categories	13
9.2	Example of control cabinet layout	15
10	Switched inductances, clock-controlled devices	16
10.1	Spark quenching	16
11	Frequency converters	17
11.1	Shielding of motor cables	17
11.2	Filtering of converters	18
11.3	Power chokes	18
11.4	Line filters	18
11.5	Motor line chokes / motor line filters	20

Revision

Rev.	0.1	950911-M.Koch	First draft
Rev.	1.0	950924-M.Koch	First version issued
Rev.	1.1	970120-M.Koch	Section on Grounding
Rev.	1.2	971001-M.Koch	Addition to section on Frequency Converter
Rev.	1.3	981104-M.Koch	Addition to section on Frequency Converter
Rev.	1.4	990525-M.Koch	Addition to section on Frequency Converter, section on Ferrite inserted
Rev.	1.5	000218-M.Koch	Addition to section on Shielding
Rev.	1.6	000519-M.Koch	English Translation

1 Purpose of these Guidelines

These wiring guidelines are addressed to plant and control system designers who are confronted with the standards for electromagnetic compatibility (EMC). They are also addressed to electrical installation specialists, who also assume responsibility during wiring and installation of the plant for ensuring EMC. In this sense, a certain knowledge of this subject is indispensable.

The purpose of this document is to assure EMC by including it in the conception phase and in the regular production process.

If all the suggestions and rules specified in these Guidelines are carefully observed, there will be a high degree of probability that the product will achieve CE conformity without any additional expenditures and at minimized cost, and that it will be robust when exposed to interference at the customer's site.

The measures for reducing the susceptibility of the machine or plant to trouble will also have a positive effect on the emissions of the products.

2 Input filters, line filters

2.1 Filtering of assemblies

Basically, it is advisable to provide all decentralized control modules, transducers, electronic assemblies, etc. with a line filter unless they already have an internal filter adequately meeting the requirements. See also Section 11.2 Filtering of converters.

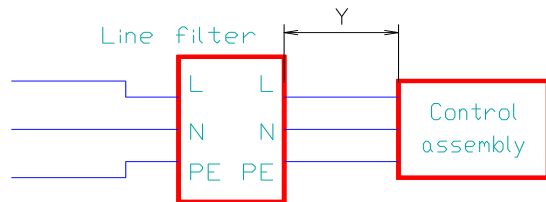

Fig. 1 Correct filtering of an assembly

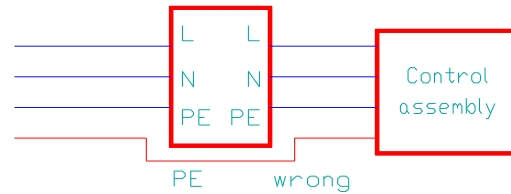

Fig. 2 Incorrect filtering of an assembly

Observe the following points:

- Mount the filter on a bare, conductive base which is part of the ground (earth) of the device.
Isolated filters will not discharge interference and will be ineffective.
- The distance Y between the filter and the assembly must be as short as possible. (cm)
- Filter input and output conductors must not be installed in parallel.
- If possible, do not install any other lines in parallel on the cable section Y.
- Run all pole, neutral and ground conductors through the filter. (Fig. 1, Fig. 2,)
Capacitive and inductive coupling.

2.2 Line entry filter

A line filter must be provided for the low-voltage entry into control cabinets, devices, etc.
Reduces interference coupling and interference emission.

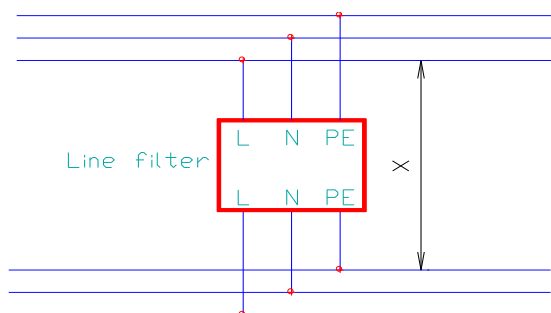

Fig. 3 Line filter

In order to achieve the full effectiveness of the filter, observe the following points:

- Mount the filter directly at the cable entry onto a metallic base.
If the filter is mounted too far away from the cable entry, conducted interference may reach the inside of the cabinet and disperse, or will exit the cabinet.
- Avoid parallel cable runs on the filter input and output lines.
- The distance X between the input and output lines must be minimum 10..20cm.

The ground connection at the filter casing is no EMC protection feature, but a safety measure to prevent unintentional contact.

3 Ferrite

3.1 Filter types

Vacuum melt ferrites

Ferrites with maximum permeability. Only to be used for balanced interference, as they very quickly reach the saturation region in the presence of asynchronous interference. (For example for devices with double insulation → only phase and neutral conductors)

3.2 Applications

Filtering of low-frequency, conducted, balanced interference

If not even high capacitances (8µF) produce any improvements in the range starting at 150kHz in the presence of balanced interference, it is possible to substantially improve filter effectiveness using iron powder ferrites:

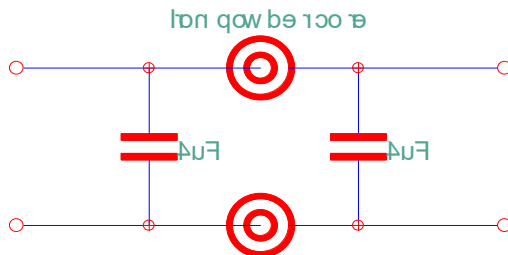

Fig. 4 Iron powder core

Instead of an 8µF capacitor, two 4µF capacitances are connected in parallel. Two iron powder cores are interposed. The inductances produce an optimal mismatch between the source and the load so that the filter effectiveness is improved.

4 Shielding

Sensitive lines such as analog signal lines, data transmission lines, measurement lines, etc. are protected against interference by shielded cables. The proper installation of the shield is crucial for the effectiveness of shielding.

The shield has the function of extending the „casing“ around the cable.

A shield bar must be provided at the cable entry into the control cabinet. This bar must be connected to the mounting plate or the chassis so that good conduction is ensured. All shields are to be connected to this bar. Suitable fasteners include metallic clamps allowing contacting of the shield around the entire circumference. (Fig. 5)

Ensuring contact around the entire circumference is essential in shield installation. Poor ground connections will become apparent in the presence of powerful electromagnetic fields.

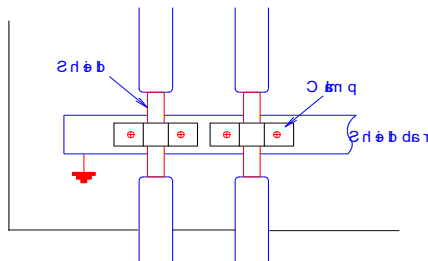

Fig. 5 Shield grounding using clamps

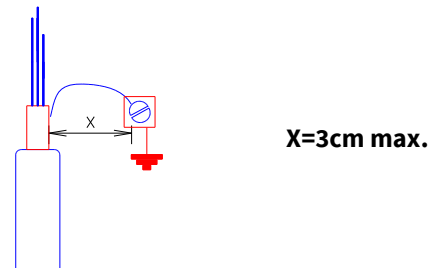

Fig. 6 Shield grounding using wire

Shields that cannot be directly grounded through a busbar or be directly connected to the device ground may be connected to the ground with maximum 3cm long leads (X). (Fig. 6)

The protruding wires must be as short as possible (max. 3cm). They must not be installed in parallel with other wires exposed to possible interference.

4.1 Bonding conductor

Cable shields are as a rule connected at both ends. Across large distances and between individual machine components, it may be necessary to install a bonding conductor ($\geq 6\text{mm}^2$) in parallel with the shielded cable in order to discharge possible equalization or stray currents.

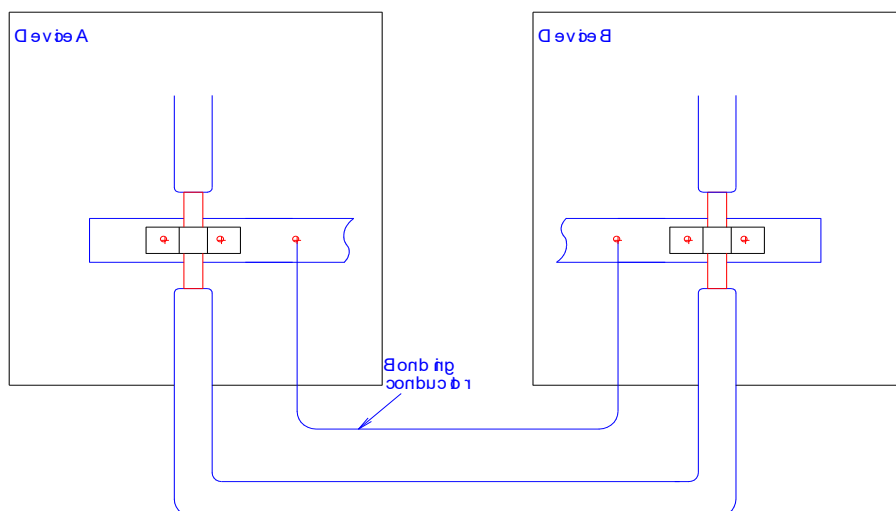

Fig. 7 Bonding conductor

It is possible to connect the shield with a capacitor on one side. (A ZNR, multilayer varistor in parallel with the capacitance will prevent any capacitor breakdown in the presence of a burst or ESD.)

If this measure is taken, no bonding conductor is required.

4.2 Ground conductor

Round cross-sections have a very inductive effect with rapid interference. In addition, the conductivity of the conductor will diminish due to the skin effect. (High-frequency currents flow only on the surface of the conductor.)

With flat conductors (side ratio 1 : 10), inductance is very much lower.

Flat ground conductors are better for ground connections exposed to heavy interference. Electrostatic discharges (ESD) via the bonding conductor are more readily discharged when flat conductors are used.

4.3 Interface cables

Pay special attention to interface cables, e.g. RS232.

Connectors:

- Always use metallic or metallized connector housings. The connector housing on the device must be installed so that good contact is ensured with the metallic housing of the device; if necessary, install springs in between.
- The shield must not be installed over a pin of the connector. To achieve complete protection, it must be connected in the housing. (Roll back the shield braid over the jacket and fasten it while relieving mechanical tension.)
- Always ground cable shields at both ends.

Communication links may also be very effectively protected against electromagnetic interference by twisted pair wires.

Note:

With parallel twisted pair lines where there is a possibility of mutual interference, take care to ensure that the mesh width of the twisting is not identical.

5 Grounding (earthing)

5.1 Cabinet grounding

Ground control cabinet doors using at least three ground straps. A single piece of wire serving for protection against contact will not provide adequate EMC protection.

5.2 Kupal

Connections between copper and aluminum (e.g. with busbars) are preferably made of Kupal.

6 Cabinet lighting

Fluorescent lamps produce very powerful electric fields in their immediate vicinity. Therefore, no fluorescent lamps should be used for lighting the inside of a cabinet.

If for some reason it is not possible to do without fluorescent lamps, the connection cable must be shielded along its entire length. Install the fluorescent tube in a metallic housing; it may be necessary to cover the lamp by a wire braid if very sensitive components are located just underneath the lamp.

7 Protection against ESD

Install control panels, keyboards, etc. that are fitted to the machine in a metallic housing. Accessory devices in plastic housings cause ESD problems. Ensure good grounding of the housing. A normal ground conductor ($\geq 6\text{mm}^2$) will in most cases be adequate to remove discharge currents. The currents will reach an intensity of 5...300A.

The ground conductor should be spatially separated from the other wiring in order to reduce coupling effects.

If the low-voltage guidelines for protection against contact are observed, no ESD problems should be encountered with housing covers, dividing walls, etc. Take care to ensure that the ground connections are as short as possible. Possibly use ground straps.

As a result of the high discharge currents, significant voltage drops may be created even by low junction resistances, which will affect the logic assemblies.

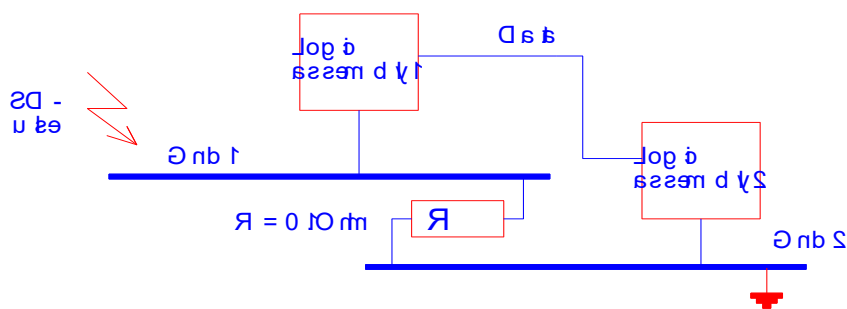

Fig. 8 ESD malfunction

The example above shows the importance of low-ohmic ground connections. An ESD pulse with a current intensity of 50A will generate a voltage drop of 5V across the junction resistance R from Gnd 1 to Gnd 2! As both logic assemblies are directly connected to ground, and because they interchange data, a malfunction will be caused when an electrostatic discharge takes place.

If the resistance R increases by a factor of 10, this may suffice to cause destructions.

All mechanical elements of a machine frame, chassis, etc. should be connected so as to be conductive at their connection points. The relevant points must be masked before any powder or paint coating is applied. If this is not possible, ground straps or screw fasteners can be used.

8 Capacitive limit switches

Since capacitive limit switches are very susceptible to interference, and since they are in addition usually operated with unshielded cables, proper installation is especially important. Note that the sensitive part of proximity switches is located in the tip of the limit switch.

When frequency converters are used in the same machine or plant, it is particularly important to observe these notes.

8.1 Installation of sensors

The metallic limit switch must be fastened at its rear end to ensure that the interference cannot flow through the proximity switch but will be discharged directly to ground.

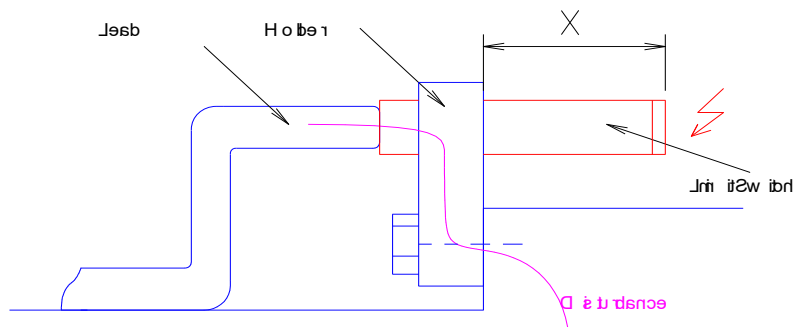

Fig. 9 Installation of proximity switch

8.2 Wiring of sensors

For a number of proximity switches, the maximum allowable unshielded wiring length is 2m; if in any way possible, this fact must be taken into account. It will suffice to install the limit switch leads in a metallic pipe or a metallic cable duct, but only with cables of the same category (see Sect. 9). Open leads must be installed above a metallic base surface. This will enable interference to be discharged by capacitance to ground, and coupling via the air, e.g. from radio sets, cellular phones, etc., will be reduced.

8.3 Application

When sensors are exposed to interference, their switching hysteresis may sometimes shift massively. As a consequence, substantial errors may occur in applications where the sensed object moves slowly toward the proximity switch.

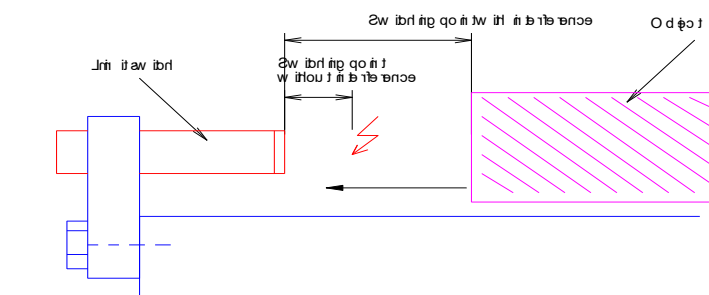

Fig. 10

Sensors with particularly critical settings will also react much more sensitively to interference, e.g. when material is sensed through acrylic glass or similar materials.

9 Cable installation

9.1 Cable categories

Cables are divided into different EMC categories:

- | | | |
|---|------|--|
| 1. Causing heavy interference, insensitive | e.g. | frequency converters, cables carrying high power, voltages above 1000VAC |
| 2. Causing interference and insensitive | e.g. | motor cables, lines with switched inductances |
| 3. Causing no interference and insensitive | e.g. | ohmic consumers, digital lines (16p I/O) |
| 4. Causing no interference and sensitive | e.g. | analog signals in the mA or V range, proximity switches |
| 5. Causing no interference and very sensitive | e.g. | temperature elements, pressure sensors, communication lines |

Cables and cable bundles of different categories must be installed at different distances from one another. The following table shows these distances:

Category [cm]	1	2	3	4	5
1	-	5	10	15	20
2	5	-	5	10	15
3	10	5	-	-	-
4	15	10	-	-	-
5	20	15	-	-	-

Tab. 1 Cable categories

In control cabinets, one cable duct system must be provided for each cable category. Only cables of the same type are allowed to be installed together in bundles. The same also applies to cable installations outside the control system.

If cables of different categories have to be connected on the same cable bar, the distances specified in Tab. 1. are applicable to the distance X in Fig. 11.

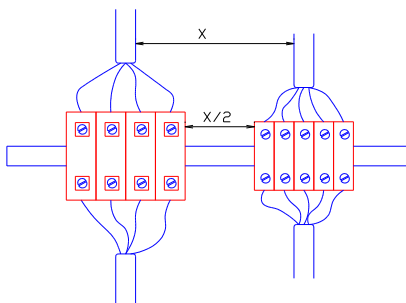

Fig. 11 Terminals

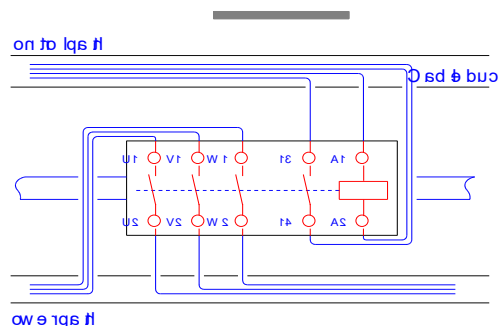

Fig. 12 Contactor wiring

Fig. 12 shows an example of separate cable installation (contactor wiring).

The greater the density with which the cables are installed above a metallic base surface, the lower the interference that can be coupled in and the greater the interference that is discharged by capacitance to the ground.

9.2 Example of control cabinet layout

The following figure shows a general example of the cable configuration and of the components inside a control cabinet.

A distinction is made between three cable categories: power lines, digital and analog lines. Each cable type must be installed in separate cable ducts. When arranging the terminals, observe Fig. 11 .

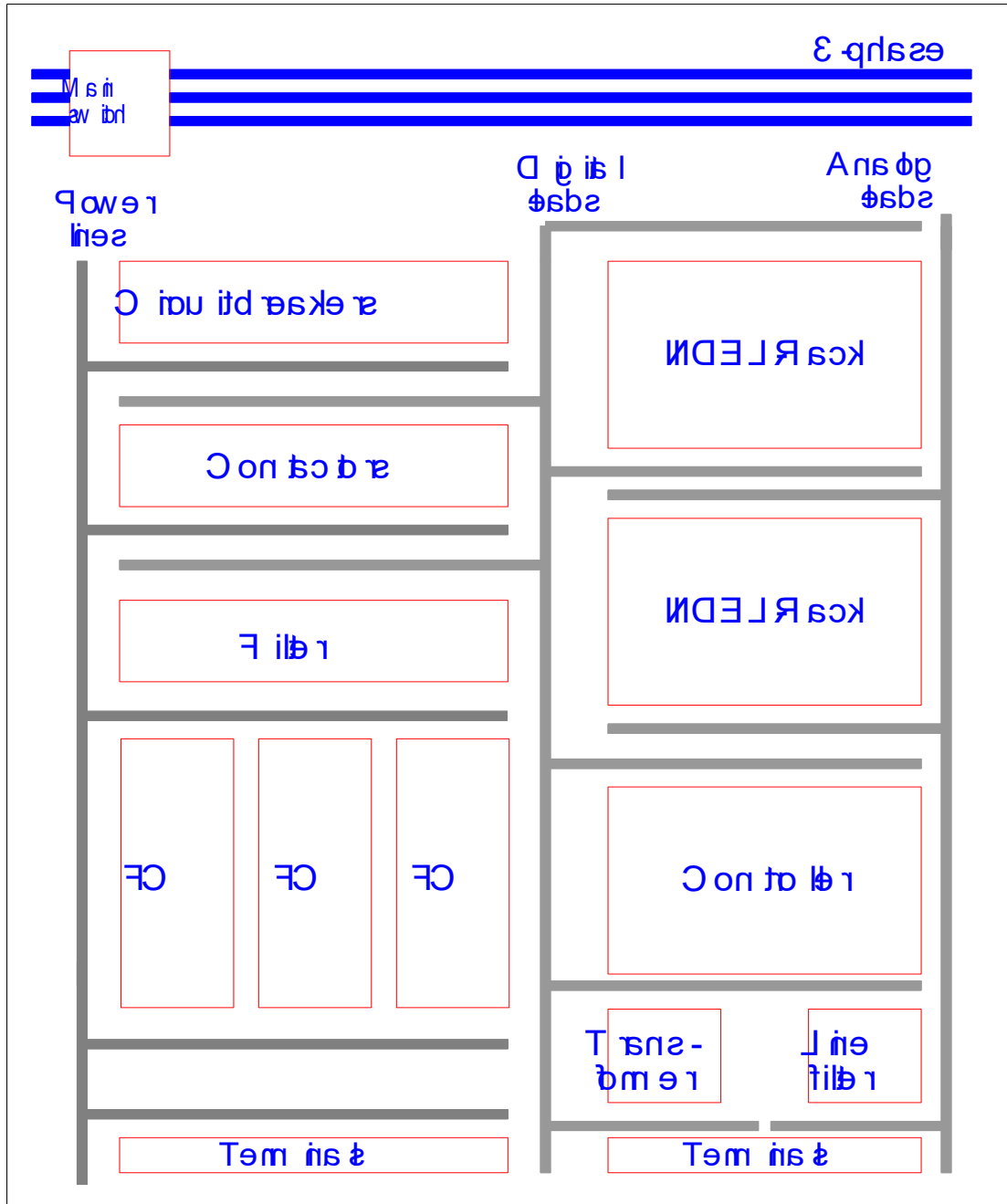

Fig. 13 Control cabinet layout

10 Switched inductances, clock-controlled devices

Switched inductances and clock-controlled devices generate burst pulses. Care must be taken when such components are operated together with control units, or proximity switches connected to the same power supply (e.g. 24V).

Improper wiring may result in malfunctions or even the destruction of elements.

Some examples:

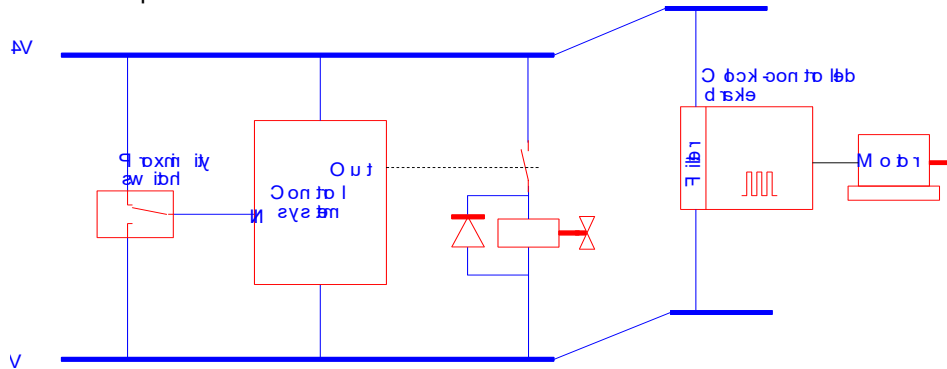

Fig. 14 Switched inductances

The solenoid valve must be provided with a free-wheeling diode, since the control system is connected to the same 24V power supply.

The same applies to the clock-controlled brake: It must be provided with a line filter to ensure that the capacitive or inductive limit switch is not damaged.

If the switched inductance (e.g. contactor, solenoid valve AC, DC) is located not in the same cabinet, but for example in a contactor cabinet, and if the switching process also takes place in the contactor cabinet, wiring with RC elements etc. is not necessary.

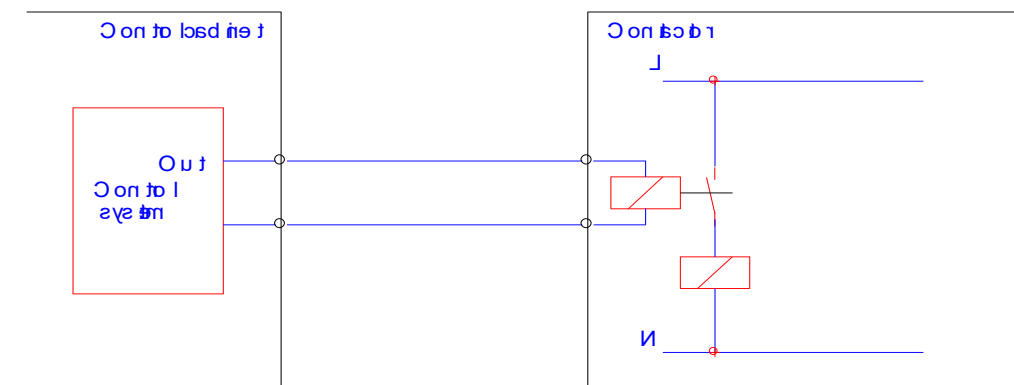

Fig. 15 Contactor wiring

Wiring of contactor, see Sect. 9, Fig. 12

10.1 Spark quenching

Switched inductances in direct-voltage circuits are provided with a free-wheeling diode.

Switched inductances in alternating-voltage circuits are damped with RC elements.

11 Frequency converters

Frequency converters, clock-controlled DC motor controllers and stepping motors are the sources of the most powerful interference. If these devices are incorrectly installed with regard to EMC measures, malfunctions will be inevitable.

It is mandatory to use shielded motor cables, on the one hand in order to prevent direct interference with sensitive devices, and on the other hand to control emissions.

All specifications made in connection with frequency converters also apply to clock-controlled servo-drives, DC motor controllers, stepping motors and converters.

11.1 Shielding of motor cables

Both ends of the shield must be connected. At the motor end, the shield can be connected to the housing. At the frequency converter end, care must be taken to ensure that the shield can be connected directly to the converter. This will allow the interference currents to flow back directly to the source. Interference currents through the shield may be as high as 5 ... 20A!

The shield leads must not be longer than 3cm; ideally, shield clamps should be used.

If motor cables run through terminal strips out of the cabinet, the shield must run through an isolated terminal. Whenever possible, connect the shield at the cabinet entry point and connect the shield directly to the frequency converter. Otherwise, in its immediate vicinity.

Needless to say that the shield must be connected to the terminal with the shortest possible leads.

The interference currents must be returned directly to the source (frequency converter). If the shield is connected to the terminals, this will produce base coupling.

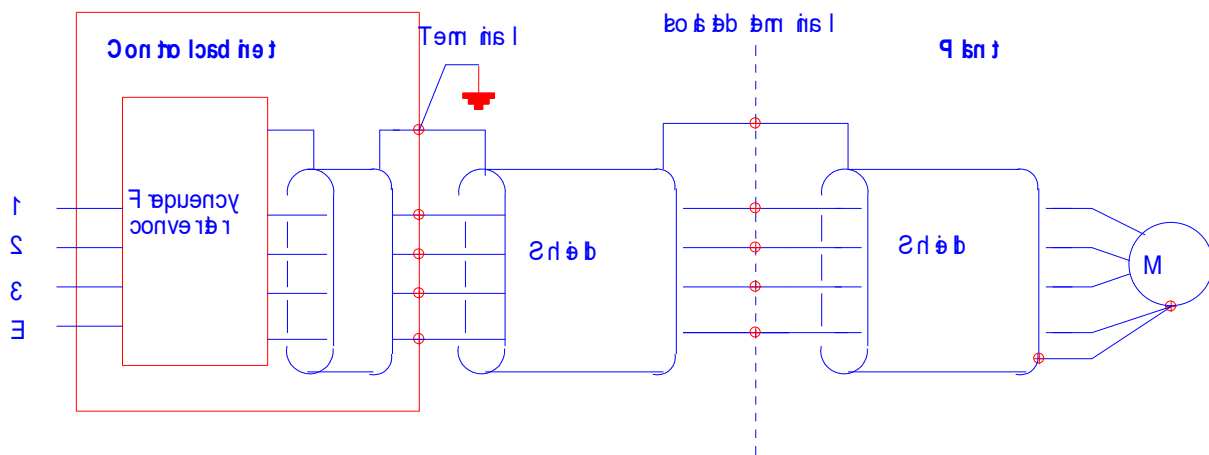

Fig. 16 Shielding of frequency converters

11.2 Filtering of converters

Filtering of converters can be done at various points with different effects. In order to fulfill the requirements of the EMC Guidelines, the application of line filters is mandatory.

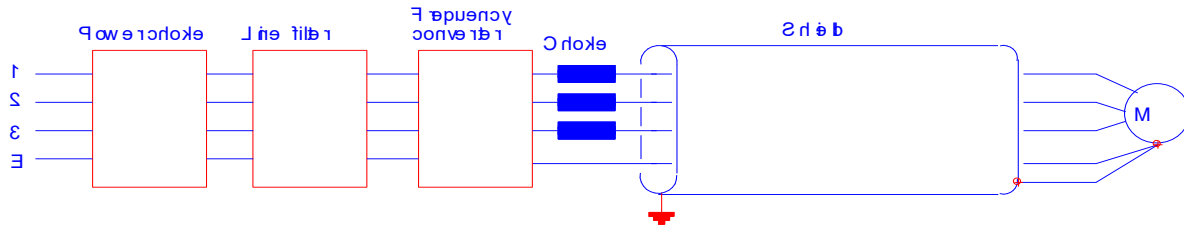

Fig. 17 Filtering of frequency converters

11.3 Power chokes

Power chokes are applied with frequency converters when the harmonics generated by a frequency converter are intolerable. Another advantage is the damping of voltage peaks which may occur in power supply networks and which could destroy the frequency converters.

11.4 Line filters

Line filters eliminate high-frequency interference which, returning to the power supply, may interfere with other devices.

Line length

The interference caused by frequency converters also depends greatly on the motor line length. In other words, not every filter will meet the requirements if the motor line length is very long (>20 ... 100m).

Filter sizing

In sizing filters, observe the **maximum current** required by the motor. If the filter is selected only for the rated current, the ferrite cores in the filter will enter the saturation region when peak currents are drawn. In the saturated state, ferrite core damping is massively reduced. The rated current of the filter must therefore be selected for a minimum supply voltage and a maximum load.

Since common line filters are only effective from approx. 100..300kHz, it is not always possible to eliminate interference even by line filters if they are below these frequencies. Long lead lengths will increase low-frequency interference.

For example, if a capacitive proximity switch typically operating at 150kHz is exposed to frequency converter interference which acts via the power supply back on the supply unit of the proximity switch, this interference cannot be eliminated by a frequency converter line filter which is only effective at 300kHz and higher.

Magnetization vs. temperature

The magnetization curve of MnZn is greatly dependent upon the temperature. At room temperature, a flux density of 350 tesla is measured. When the temperature rises to 100 °C, the flux density will diminish to 250 tesla; the choke enters the saturation region more quickly.

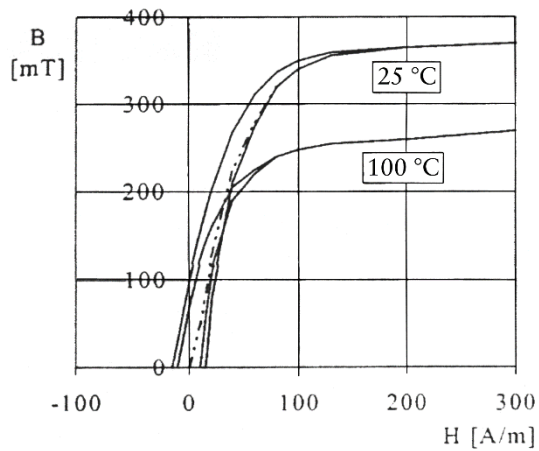

Fig. 18 Filtering of frequency converters

Filter efficiency vs. power supply voltage

The supply voltage of frequency converters normally varies between 400 and 480V, i.e. the intermediate circuit voltage changes between 565 and 479V. The effectiveness of the input filter may change in this voltage range by as much as 2 ... 4dB. The poorest filter efficiency will be encountered at the highest voltage.

11.5 Motor line chokes / motor line filters

Interference through the motor lines can be eliminated by appropriate motor line chokes or motor line filters.

Install individual motor line chokes for each phase. Motor line chokes with a normal iron core must be correctly sized, i.e. the allowable clock frequency of the frequency converter installed ahead must be observed. The current loading must not drive the choke into the saturation region, as it would otherwise become ineffective. It is advisable to apply the chokes recommended by the frequency converter supplier. In addition to allowing interference to be reduced, such chokes can also suppress or at least reduce unpleasant motor noise such as is caused by frequency converters. The frequency range of such chokes is greatly limited toward the top.

Motor line chokes with ferrite cores, on the other hand, are only effective at frequencies starting at a few MHz. Such chokes can be “home-made” by making a few turns of each motor phase line around the ferrite core of each phase.